

TOLLING REGULATIONS FOR THE MOTORWAYS AND EXPRESSWAYS OF AUSTRIA

Authorised in accordance with § 14 para. 2 of the Federal Road Toll Act 2002 and with regard to Part A II, adopted by decree by the Federal Minister of Climate Action, Environment, Energy, Mobility, Innovation and Technology in agreement with the Federal Minister of Finance

GZ: 325.009/1-I/K2-2003

last amendment

2024-0.436.728

Valid from 1st July 2024

Version 79

Table of contents

TABLE OF CONTENTS	2
PREAMBLE.....	8
PART A I: TOLLING REGULATIONS FOR SINGLE-TRACK MOTOR VEHICLES AND MULTI-TRACK MOTOR VEHICLES MOTOR VEHICLES WITH A MAXIMUM TECHNICALLY PERMISSIBLE LADEN MASS OF NO MORE THAN 3.5 T	10
1 GENERAL REGULATIONS	10
1.1 DEFINITION OF TERMS	10
1.2 SCOPE OF APPLICATION.....	10
1.3 VIGNETTE OBLIGATION	11
1.3.1 Road network where tolls must be paid.....	11
1.3.2 Signage.....	13
1.3.3 Exceptions from vignette obligation	14
1.4 VIGNETTE PRICES	17
1.5 DURATION OF ENTITLEMENT OF USE	17
1.5.1 Annual vignette.....	17
1.5.2 Two-month vignette.....	17
1.5.3 Ten-day vignette.....	18
1.5.4 One-day vignette	18
1.6 RELIEF MEASURES	18
1.6.1 Vignettes free of charge for people with disabilities.....	18
1.6.2 Right to reimbursement of vignettes issued for disabled persons.....	19
1.7 OBLIGATIONS.....	19
1.8 MONITORING COMPLIANCE WITH THE VIGNETTE OBLIGATION	20
1.8.1 Inspection by road inspection authorities and toll enforcement officers.....	20
1.8.2 Automatic vignette monitoring.....	22
1.9 TOLL EVASION.....	22
1.9.1 Penalties for toll evasion.....	22
1.9.2 Non-imposition of a penalty	23
1.9.3 Substitute toll	23
1.10 VIOLATION OF THE OBLIGATION TO STOP	26
1.11 DATA PROTECTION AND DATA SECURITY	26
1.12 JURISDICTION AND APPLICABLE LAW	26
1.13 RESPONSIBILITY AND CUSTOMER SERVICE (ASFINAG SERVICE CENTER)	26
2 FURTHER REGULATIONS WHEN USING A TOLL STICKER.....	27
2.1 SALE OR DISTRIBUTION OF THE TOLL STICKER.....	27
2.2 ATTACHING THE TOLL STICKER.....	27
2.2.1 Where and how to attach the toll sticker.....	27
2.2.2 Permissibility of carrying an unattached toll sticker in the vehicle.....	28
2.3 TOLL STICKER REPLACEMENT	28
3 FURTHER REGULATIONS WHEN USING A DIGITAL VIGNETTE.....	29
3.1 AVAILABILITY OF THE DIGITAL VIGNETTE	29
3.2 OBTAINING THE DIGITAL VIGNETTE.....	29
3.2.1 Procurement of the digital vignette via the ASFINAG toll shop and authorised online distribution partners	29
3.2.2 Purchase of the digital vignette at an ASFINAG vending machine	31
3.2.3 Procurement of the digital vignette at ASFINAG toll stations and points of sale.....	32
3.2.4 Means of payment	32

3.2.5	Further Services.....	33
3.2.6	Terms of use.....	34
3.3	RIGHT OF WITHDRAWAL.....	34
3.4	SPECIFICS FOR ENTREPRENEURS CONCERNING THE PURCHASE OF A DIGITAL VIGNETTE.....	35
3.5	POSSIBLE CHANGES BEFORE THE BEGINNING OF VALIDITY.....	35
3.6	RE-REGISTRATION FROM THE BEGINNING OF VALIDITY.....	36
3.6.1	Re-registration without giving reasons.....	36
3.6.2	Re-registration in certain cases.....	37
3.6.3	Conditional re-registration in the ASFINAG toll shop.....	38
3.6.4	Re-registration via the ASFINAG Service Center.....	39
3.6.5	Re-registration at ASFINAG toll stations and selected points of sale.....	39
3.6.6	Re-registration of the digital vignette and the digital section toll.....	40

PART A II: TOLLING REGULATIONS FOR SINGLE-TRACK MOTOR VEHICLES AND MULTI-TRACK MOTOR VEHICLES WITH A MAXIMUM TECHNICALLY PERMISSIBLE LADEN MASS OF NO MORE THAN 3.5 T FOR THE EXISTING SECTION TOLLS ON THE AUSTRIAN MOTORWAY AND EXPRESSWAY NETWORK: A 9, A 10, A 11, A 13, S 16.....

1	GENERAL REGULATIONS.....	41
1.1	DEFINITION OF TERMS.....	41
1.2	SCOPE OF APPLICATION.....	41
1.3	JURISDICTION AND APPLICABLE LAW.....	42
1.4	RESPONSIBILITY AND CUSTOMER SERVICE (ASFINAG SERVICE CENTER).....	42
2	PAYMENT OF THE SECTION TOLL.....	43
2.1	ROUTES SUBJECT TO TOLLS.....	43
2.1.1	Designation of the section toll segments and toll stations.....	43
2.1.2	Signage.....	44
2.2	LANE GUIDANCE.....	44
2.2.1	Closed toll lane operation A 9, A 10, A 11, A 13, S 16.....	44
2.2.1.1	Mixed toll lane operation at the A 10 and A 13 secondary toll stations.....	45
2.2.2	Open toll lane operation.....	45
2.2.2.1	Open toll lane operation on A 10, A 11 and S 16.....	46
2.2.2.2	Open toll lane operation on A 9.....	46
2.2.2.3	Open toll lane operation at the Schönberg A 13 toll station.....	47
2.2.3	Special obligations to cooperate A 9 and A 13.....	48
2.3	EXEMPTIONS FROM THE TOLL OBLIGATION.....	48
2.3.1	Permanent exemptions.....	48
2.3.2	Temporary exemptions.....	49
2.3.2.1	Exceptions for humanitarian aid transports.....	49
2.3.2.2	Exemptions at the request of the Federal Ministry of the Interior in the context of state crisis and disaster control management or international disaster aid.....	50
3	TOLL RATES.....	50
3.1	STANDARD TOLL RATES.....	51
3.1.1	A 9 Gleinalm and A 9 Bosruck.....	51
3.1.2	A 10 Tauern/Katschberg.....	51
3.1.3	A 11 Karawanken.....	51
3.1.4	A 13 Brenner.....	51
3.1.5	S 16 Arlberg road tunnel.....	52
3.2	TYPE OF RATES.....	52
3.2.1	Single trip.....	52
3.2.2	Annual card.....	52
3.2.3	Multi-trip card.....	52

3.2.4	Multi-trip card for commuters.....	52
3.2.5	Multi-trip card for people with disabilities	53
3.2.6	Multi-trip card for disabled persons on the A 13	53
3.2.7	Monthly card for the A 13	54
3.2.8	Multi-trip resident’s card for the A 13	54
3.2.9	14-trip monthly card for the A 11	54
3.3	LOSS OF LICENSE PLATE NUMBER RELATED CARDS.....	54
4	PAYMENT METHODS	54
4.1	PAYMENT AT THE ASFINAG toll station	54
4.2	PURCHASE IN ADVANCE	55
4.2.1	Procurement via the ASFINAG toll shop and authorised online distribution partners: Payment in advance – Pre-Pay.....	55
4.2.2	Pre-registration in the ASFINAG toll shop and with authorised online distribution partners: payment afterwards – digital section toll FLEX.....	55
4.2.3	Procurement from ASFINAG vending machines.....	56
4.2.4	Purchase at points of sale	56
4.2.5	Means of payment	57
4.3	ADDITIONAL SERVICES (“My Account”)	57
4.3.1	General services.....	57
4.3.2	Digital subscription in the personal user account ("My Account").....	57
4.3.3	Retrospective payment of single trip (digital section toll FLEX) in the personal user account ("My Account").....	58
4.4	Terms of use.....	58
4.5	RIGHT OF WITHDRAWAL	58
4.6	SPECIFICS FOR ENTREPRENEURS.....	59
4.7	POSSIBLE CHANGES	59
4.8	RE-REGISTRATION FROM THE BEGINNING OF VALIDITY	60
4.8.1	Re-registration without giving reasons	60
4.8.2	Re-registration in certain cases.....	61
4.8.3	General provisions for re-registration	61
4.8.4	Re-registration of the digital vignette and the digital section toll.....	62
5	DATA PROTECTION AND DATA SECURITY	63
6	MONITORING CORRECT PAYMENT OF THE SECTION TOLL.....	63
6.1	TOLL ENFORCEMENT OFFICERS.....	63
6.2	CONFISCATION OF LICENSE PLATE NUMBER RELATED CARDS	65
7	TOLL EVASION.....	65
7.1	PENALTY FOR TOLL EVASION AND FOR VIOLATING A DRIVING BAN ORDERED BY THE STVO.....	65
7.2	NON-IMPOSITION OF A PENALTY	66
7.3	SUBSTITUTE TOLL	66
7.3.1	Method of payment	66
7.3.1.1	Request by toll enforcement officers	66
7.3.1.2	Retrospective summons process.....	66
7.3.2	Substitute toll rate.....	67
7.3.3	Continued journey.....	68
7.3.4	Payment of the substitute toll	68
8	VIOLATION OF THE OBLIGATION TO STOP	68
PART B: TOLL REGULATIONS FOR MULTI-TRACK MOTOR VEHICLES WITH A MAXIMUM TECHNICALLY PERMISSIBLE LADEN MASS OF MORE THAN 3.5 T.....		69
1	GENERAL INFORMATION	69
2	SCOPE OF APPLICATION.....	70

3	TOLL OBLIGATION	70
3.1	Road network subject to tolls	70
3.1.1	Areas with existing road tolls	71
3.1.2	The toll obligation in areas around road works	73
3.1.3	Temporary entrances and exits in accordance with Section 26 (2) of the Federal Highways Act	73
3.2	Signage.....	74
3.3	Exemptions from the toll obligation.....	74
3.3.1	Permanent exemptions.....	74
3.3.2	Time-limited exceptions	76
3.3.3	Special exemptions	77
3.4	Relief measures for people with disabilities.....	77
4	TOLL RATES.....	78
5	REGISTERING WITH AND DEREGISTERING FROM THE TOLL SYSTEM.....	81
5.1	General information	81
5.2	Declaration of rate-relevant characteristics (CO ₂ emission class, EURO emission class).....	81
5.2.1	Declaration of the CO ₂ emission class	83
5.2.2	Declaration of the EURO emission class	84
5.2.3	Provision of evidence and verification of rate-relevant characteristics (CO ₂ emission class, EURO emission class)	85
5.2.4	Documents that are suitable as proof of rate-relevant characteristics (CO ₂ emission class, EURO emission class)	90
5.2.5	Renewed declaration of rate-relevant characteristics.....	90
5.3	GO points of sale.....	91
5.4	Processing fee.....	92
5.5	Payment Procedure.....	92
5.5.1	General information	92
5.5.2	About the post-pay procedure	92
5.5.3	About the pre-pay process	92
5.6	Data storage.....	93
5.6.1	General information	93
5.6.2	Obligation to promptly disclose changes to the data to be stored in accordance with item 5.6.1.....	93
5.6.3	Sale of motor vehicles	94
5.6.4	Rental of motor vehicles	96
5.6.5	Interchangeable license plates	97
5.6.6	Test drivers and motor transfer trips.....	98
5.7	Regulations for the GO-Box.....	101
5.7.1	General information	101
5.7.2	GO-Box: period of validity, guarantee, exchange, bearing of costs, and recall	102
5.7.3	Theft, loss, and deactivation of the GO-Box	103
5.7.4	De-registration, returning the GO-Box, and the lapse of toll credit	104
5.7.5	Transportation of GO-Boxes without the obligation to pay the toll obligation.....	105
6	INDIVIDUAL SERVICE INFORMATION AND COLLECTIVE INVOICE	105
6.1	Itemised toll information sheets.....	105
6.2	collective invoice	105
7	RETROSPECTIVE PAYMENT OF THE TOLL.....	106
7.1	Retrospective payment at GO points of sale/toll enforcement officers.....	106
7.2	Central additional payment if an incorrect category or incorrect toll rate group is used ...	107
7.3	Retrospective settlement.....	108
8	OBLIGATIONS OF MOTOR VEHICLE DRIVERS.....	108

8.1	The correct installation of the GO-Box	108
8.2	Proper operation of the GO-Box	109
8.2.1	Example illustration of the GO-Box.....	109
8.2.2	Declaration and setting of the category (not applicable for buses and motor homes).....	110
8.2.3	Declaring and setting the vehicle category (buses and motor caravans)	110
8.2.4	Checking the functionality of the GO-Box	111
9	MONITORING ADHERENCE TO THE TOLL OBLIGATION.....	114
9.1	Toll enforcement officers and their powers	114
9.2	Toll enforcement officers' identification cards	115
9.3	Toll enforcement officers' vehicles.....	115
10	TOLL EVASION.....	116
10.1	Penalties for toll evasion.....	116
10.2	Non-imposition of a penalty	116
10.3	Substitute toll	116
10.3.1	Method of payment.....	116
10.3.2	Substitute toll rate	117
10.3.3	Initiation of administrative penal proceedings.....	118
11	DATA PROTECTION AND DATA SECURITY	118
12	VIOLATION OF THE OBLIGATION TO STOP	119
13	PLACE OF JURISDICTION AND APPLICABLE LAW	119
14	RESPONSIBILITY AND CUSTOMER SERVICE (ASFINAG SERVICE CENTER)	119
15	RATE GROUP FOR BUSES FROM 1 JANUARY 2025	119
15.1	Declaration of the vehicle's status as a bus.....	119
15.2	Proof and test of the vehicle's status as a bus or coach	120
PART C: INTEROPERABILITY		121
1	THE AUTHORISATION OF ON-BOARD UNITS USED FOR THE SWISS LSVA TOLL SYSTEM....	121
1.1	General information	121
1.2	Provisions relating to the on-board unit	122
1.3	Registration.....	122
1.3.1	Registration process.....	122
1.3.2	Declaration of rate-relevant characteristics (CO ₂ emission class, EURO emission class) and data modification	122
1.4	Data exchange	123
1.5	Obligations of motor vehicle drivers	123
1.5.1	The correct installation and operation of the on-board unit and the setting of the category in the on-board unit.....	123
1.5.2	Checking that the on-board unit is in working order	123
1.6	Signals emitted by the on-board unit.....	124
1.7	De-registration.....	124
2	DUAL-CONTRACT INTEROPERABILITY WITH GERMANY ("TOLL2GO")	124
2.1	General information	124
2.2	Requirements for using the service in Austria.....	125
2.3	Registration.....	125
2.3.1	Registering for the first time.....	125
2.3.2	Switching from an Austrian GO-Box to the TC OBU	127
2.3.3	Declaration of rate-relevant characteristics (CO ₂ emission class, EURO emission class)	128
2.3.4	Vehicle declaration	129
2.4	Right to refusal.....	129
2.5	The storage and exchange of data.....	130
2.6	Data changes	130

2.7	The sale or rental of vehicles.....	131
2.8	Provisions relating to the TC OBU.....	131
2.9	GO points of sale.....	132
2.10	Deregistering the TC OBU.....	132
2.11	Retrospective payment of the toll	133
2.12	Obligations of motor vehicle drivers	133
2.12.1	The correct installation and operation of the TC OBU and setting the category in the TC OBU	133
2.12.2	Checking that the TC OBU is in working order.....	134
2.12.3	Acoustic signals emitted by the TC OBU	134
3	THE AUTHORISATION OF ON-BOARD UNITS FOR TOLL PAYMENT IN AUSTRIA WITHIN THE SCOPE OF THE “EUROPEAN ELECTRONIC TOLL SERVICE” (“EETS”)	135
3.1	European Electronic Toll Service (EETS)	135
3.2	Provisions relating to the on-board unit (EETS OBU)	136
3.3	Registration with and de-registration from EETS	136
3.4	The storage and exchange of data.....	136
3.4.1	Correct toll payment with the EETS OBU	136
3.4.2	Incorrect toll payment with the EETS OBU.....	137
3.5	Obligations.....	137
3.5.1	Vehicle declaration	137
3.5.2	Installation and operation of the EETS OBU	137
3.5.3	Declaring and setting the category.....	138
3.5.4	Checking that the EETS OBU is in working order	138
3.5.5	Acoustic signals emitted by the EETS OBU.....	138
3.6	Retrospective payment of the toll	139
3.7	Responsibilities and services	140
3.7.1	EETS provider (EA).....	140
3.7.2	GO points of sale.....	140
3.7.3	ASFINAG Service Center	140
3.7.4	Special features	140
3.8	Use of the Austrian GO-Box	140

PREAMBLE

The right of usufruct to all motorways and expressways in Austria was transferred to Autobahnen- und Schnellstraßen-Finanzierungs-Aktiengesellschaft (ASFINAG) by the usufruct contract concluded on the basis of the ASFINAG Enabling Act of 1997, BGBl I No. 113/1997. ASFINAG therefore has the right to collect a toll from all users of federal roads and sections of federal roads in Austria that are subject to the right of usufruct. ASFINAG is a company incorporated under the ASFINAG act, BGBl No. 591/1982, the shares of which are wholly owned by the Republic of Austria.

References to federal laws refer – unless otherwise stated – to the respective federal law in the currently valid version.

1. In accordance with the provisions of the Federal Road Toll Act 2002 (BStMG (Federal Road Toll Acts)), BGBl I No. 109/2002, ASFINAG is entitled to levy a time-based toll or a distance-based toll on all motorways and expressways from the users of these roads, depending on the maximum technically permissible laden mass of a motor vehicle. Tolls must also be paid on all areas that are part of a federal road in accordance with section 3 of the Federal Highways Act 1971 (BStG).

In accordance with section 14 para. 1 BStMG (Federal Road Toll Acts), ASFINAG is obliged to draw up Tolling Regulations containing provisions governing the use of motorways and expressways on which tolls are collected. The present Tolling Regulations contain the following:

- General provisions for the payment of time-based tolls for motor vehicles whose maximum technically permissible laden mass does **not exceed 3.5 t** (Part A I), whereby the collection or performance of the operational tasks associated with this (Service Center for vignettes, vignette production, vignette distribution, etc.) by ASFINAG Maut Service GmbH, Alpenstraße 99, 5020 Salzburg, Austria, or by ASFINAG Service GmbH, Traunuferstraße 9, 4052 Ansfelden, Austria, and ASFINAG Alpenstraße GmbH, Rennweg 10 A, 6020 Innsbruck, Austria, are performed on behalf of and for the account of ASFINAG, and
 - General provisions for the payment of the **distance-based tolls** for motor vehicles maximum technically permissible laden mass **exceeds 3.5 t** (Parts B and C), whereby the fully electronic toll system for collecting distance-based tolls is operated by ASFINAG Maut Service GmbH, Alpenstraße 99, 5020 Salzburg, Austria, and the performance of the associated operative tasks is carried out by ASFINAG Maut Service GmbH, Alpenstraße 99, 5020 Salzburg, Austria, or ASFINAG Service GmbH, Traunuferstraße 9, 4052 Ansfelden, Austria, and ASFINAG Alpenstraße GmbH, Rennweg 10 A, 6020 Innsbruck, Austria, in the name of and for the account of ASFINAG.
2. By decree of the Federal Minister for Climate Protection, Environment, Energy, Mobility, Innovation and Technology in agreement with the Federal Minister of Finance to ASFINAG, the general provisions and toll payments with regard to section tolls on the section toll segments of the A 9, A 10, A 11, A 13 and S 16 are issued. The legal basis for the collection of **section tolls** as set out in § 32 BStMG (Federal Road Toll Acts) will be presented below according to the section toll segments:

A 9 Pyhrn motorway: The section toll is collected between the Spital am Pyhrn junction and the Ardning junction (Bosruck tunnel) and between the St. Michael intersection and the Übelbach intersection (Gleinalm tunnel). The authorisation to collect a toll is regulated by section 2(1) of the Pyhrn Motorway Financing Act, BGBl. No. 479/1971.

A 10 Tauern motorway: Section toll is collected between the Flachau and Rennweg am Katschberg junctions. This toll section includes the Tauern and Katschberg tunnels. The authorisation to collect a toll is regulated by section 2 para. 1 of the Tauern Motorway Financing Act, BGBl. No. 115/1969.

A 11 Karawanken motorway: The section toll is collected between the St. Jakob im Rosental junction and the Slovenian state border (Karawanken tunnel). The authorisation to collect a toll is regulated in Article 12 of the State Treaty on the Karawanken Tunnel (BGBl. 441/1978) and in § 2 of the Karawanken Motorway Financing Act, BGBl. No. 442/1978.

A 13 Brenner motorway: The section toll is collected between the Innsbruck-Amras or Innsbruck-Wilten intersection and the Italian state border at the Brenner pass. The authorisation to collect a toll is regulated in § 1 para. 1 of the Federal Act on the Financing of the Innsbruck-Brenner Motorway, BGBl. No. 135/1964.

S 16 Arlberg expressway: The section toll is collected between the St. Anton am Arlberg and Langen am Arlberg junctions. This section toll segment includes the Arlberg tunnel. The authorisation to collect a toll is regulated by section 2 para. 1 of the Arlberg Expressway Financing Act, BGBl. No. 113/1973.

The road section toll will be collected by ASFINAG Maut Service GmbH, Alpenstraße 99, 5020 Salzburg, Austria, on behalf of and for the account of ASFINAG.

The collection of section tolls for motor vehicles whose maximum technically permissible laden mass does not exceed 3.5 t is regulated in accordance with Part A II of these Tolling Regulations.

3. Part A I, Part B and Part C of these Tolling Regulations have been approved by the Federal Minister for Climate Protection, Environment, Energy, Mobility, Innovation and Technology in agreement with the Federal Minister of Finance pursuant to section 14 para. 2 BStMG (Federal Road Toll Act).

Part A II of these Tolling Regulations was issued to ASFINAG by decree by the Federal Minister of Climate Action, Environment, Energy, Mobility, Innovation and Technology in agreement with the Federal Minister of Finance.

Insofar as the terms used in the following refer to natural persons, the chosen form applies to all genders.

PART A I: TOLLING REGULATIONS FOR SINGLE-TRACK MOTOR VEHICLES AND MULTI-TRACK MOTOR VEHICLES WITH A MAXIMUM TECHNICALLY PERMISSIBLE LADEN MASS OF NO MORE THAN 3.5 T

1 GENERAL REGULATIONS

1.1 DEFINITION OF TERMS

- **Vignette:** The term "vignette" includes both the toll sticker and the digital vignette.
- **Valid vignette:** The toll is properly paid if either a valid toll sticker (corresponding to the vehicle type) is properly affixed to the motor vehicle (exception see item 2.2.2) or a valid digital vignette (corresponding to the vehicle type) is properly registered in the toll system for the time period of use of the road network subject to toll payment.
- **Order confirmation:** This is a document issued when a digital vignette has been obtained (registration in the toll system). This document particularly shows data of the license plate number registered in the toll system, vehicle type, validity period as well as the product-ID, which serves to clearly identify the digital vignette.
- **Acknowledgement allonge:** lower section (carrier foil) of a toll sticker
- **Vignette type:** Vehicle-related differentiation between vignettes for single-track vehicles and multi-track vehicles with a maximum technically permissible laden mass of up to 3.5 t.
- **Vignette registry:** This is a public register that anyone can use free of charge to check the period for which a digital vignette or digital section toll is registered by entering a vehicle licence plate number. The vignette registry can be found at <https://evidenz.asfinag.at/>.
- **Vehicle type:** Differentiation between single-lane vehicles and multi-track vehicles with a maximum technically permissible laden mass of up to 3.5 t.
- **Digital subscription:** A digital subscription is an unlimited procurement of digital annual vignettes or multi-trip cards similar to a subscription contract.

1.2 SCOPE OF APPLICATION

The Tolling Regulations Part A I apply to single-track motor vehicles and multi-track motor vehicles with a maximum technically permissible laden mass of no more than 3.5 t. These are subject to the time-based toll (vignette).

Unless expressly indicated otherwise, references to individual items contained in Part A I of the Tolling Regulations always relate specifically to this Part A I of the Tolling Regulations.

According to § 10 para. 3 last sentence of the BStMG [Federal Road Tolls Act], motor vehicles with three wheels are considered as single-track motor vehicles.

No time-based toll must be paid for trailers being towed by multi-track vehicles with a maximum technically permissible laden mass of no more than 3.5 t or for sidecars attached to single-track vehicles.

Drivers of multi-track motor vehicles that have not yet been registered and carry transfer license plates are obliged to pay the time-based toll as long as the service weight of their vehicle does not exceed 3.5 t. In the case of journeys with test drive or transfer licence plates, a copy of the type certificate or a confirmation of the producer or their authorised representative in accordance with

§ 29 para. 2 KFG about the tare weight of the motor vehicle must be carried along, which must be presented when requested by toll enforcement officers. If evidence of this kind cannot be presented on request, the multi-track vehicle in question shall be considered a vehicle with a service weight of more than 3.5 t.

Pursuant to § 33 para. 18 line 8 BStMG (Federal Road Toll Acts), motor vehicles with a maximum permissible weight of no more than 3.5 t at the time of use of the toll road network, that were first registered for traffic before 1 December 2023, and for which the maximum permissible weight (MPW) was set at no more than 3.5 t before 1 December 2023, are deemed to be vehicles with a maximum technically permissible laden mass of no more than 3.5 t until 31 January 2029 and are therefore subject to the time-based toll.

1.3 VIGNETTE OBLIGATION

1.3.1 Road network where tolls must be paid

Unless exemptions apply, a time-based toll must be paid for vehicles that are liable for the toll for the use of the motorways and expressways:

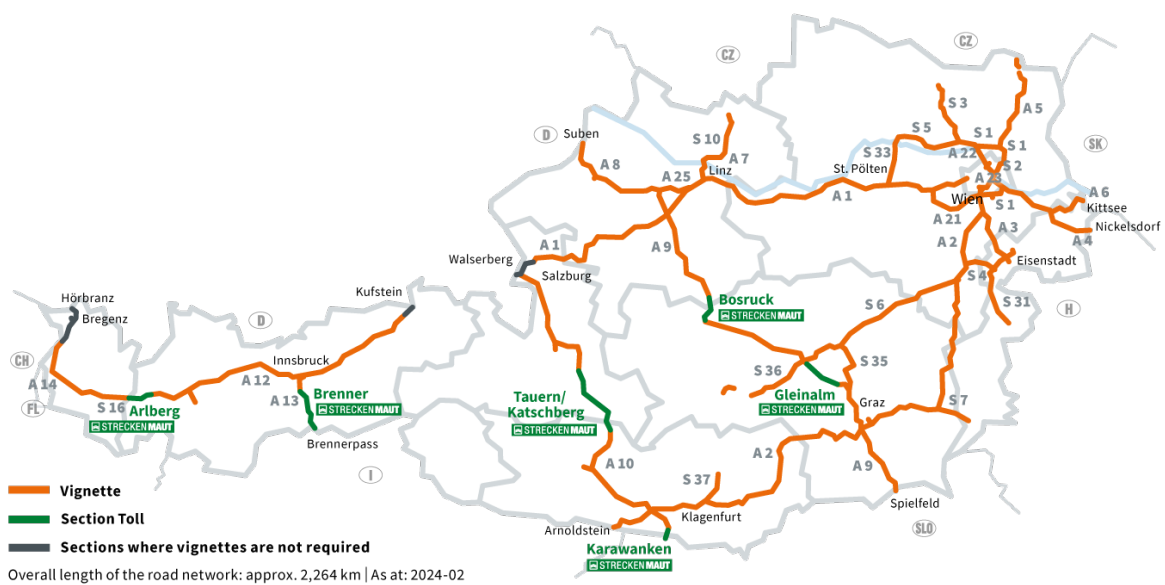

Figure 1

Toll roads in Vienna:



Figure 2

If the road network subject to tolls is extended, the toll sections added are recorded in the Appendices 4 to the Tolling Regulations (toll section rates). The time-based toll must be paid for these extensions as soon as they come into effect.

- The following motorway and expressway sections are exempt from the payment of a time-based toll (Section 13 (1a) in conjunction with Section 33 (15) BStMG (Federal Road Toll Acts)): the A 1 Westautobahn motorway between the German state border at Walsersberg and the Salzburg Nord junction
- the A 12 Inntalautobahn motorway between the German state border near Kufstein and the Kufstein-Süd junction
- the A 14 Rheintal/Walgau motorway between the German state border near Hörbranz and the Hohenems junction

The A 26 Linzer motorway (currently under construction) is only subject to the vignette obligation at the end of the day on which its connection to the A 7 Mühlkreis motorway via the Linz-Hummelhof intersection was opened to traffic.

The following motorway and expressway sections are exempt from the payment of a time-based toll in accordance with § 10 Para. 2 BStMG (Federal Road Toll Acts) and are subject to the provisions on the section toll (section toll segments, see Tolling Regulations Part A II):

- A 9 Pyhrn motorway between the Spital am Pyhrn and Ardning junctions (Bosruck tunnel) and between the St. Michael intersection and the Übelbach junction (Gleinalm tunnel)
- A 10 Tauern motorway between the Flachau and Rennweg am Katschberg (Tauern and Katschberg tunnels) junctions
- A 11 Karawanken motorway between the St. Jakob im Rosental junction and the Slovenian state border (Karawanken tunnel)
- A 13 Brenner motorway
- S 16 Arlberg expressway between the St. Anton am Arlberg and Langen am Arlberg junctions.

In accordance with the Ordinance issued by the Federal Minister for Transport, Innovation, and Technology on the exemption of national highway sections from the obligation to pay tolls (Toll Section Exemption Ordinance 2010), the following motorway and expressway sections are excluded from the obligation to pay time-based toll:

- S 5 Stockerauer expressway between the Jettsdorf intersection (S 33) and the Krems Mitte junction (B 3 state road, B 37 state road)

1.3.2 Signage

Information about the obligation to pay tolls is provided by signs at all border crossings on federal and state roads with motor vehicle traffic (Figure 3a, Figure 3b):



Figure 3a*



Figure 3b*

In addition, information signs at all slip roads to the road network subject to tolls provide information about the obligation to pay tolls (Figure 4):



Figure 4*

* Motor vehicles with a maximum technically permissible laden mass of no more than 3.5 t are subject to the vignette obligation, "GO" indicates the obligation to pay tolls for motor vehicles with a maximum technically permissible laden mass of more than 3.5 t (GO toll obligation, see Tolling Regulations Part B)

Exemptions from the vignette obligation according to section 13(1a) and (1b) BStMG (Federal Road Toll Acts) are indicated on additional information signs at border crossings and slip roads within the sections concerned (see example of the A 14 in Figure 5), respectively.



Figure 5*

1.3.3 Exceptions from vignette obligation

1.3.3.1 Permanent exemptions

The following vehicles are permanently exempt from the vignette obligation:

- Motor vehicles with visible blue headlights or warning lights in accordance with section 20(1)(4) and (5) of the Motor Vehicle Act 1967 (hereinafter referred to as 'KFG' for short). In the case of motor vehicles pursuant to § 20 para. 5 KFG, an exemption from the vignette obligation exists only for the duration of the use of the headlamp or warning light with blue light and if the conditions and requirements issued pursuant to § 20 para.6 KFG are complied with during use. On the return journey from an operation in which headlights or warning lights with blue light were used, these vehicles are also exempt from the vignette obligation.
- Motor vehicles on which headlights or warning lights with blue lights are visibly attached in accordance with § 20 Para. 5 KFG and which are registered to non-profit organisations whose tasks are carried out by members or employees who work predominantly on a voluntary basis. The regular use of motor vehicles for the purposes of these devices (or a device specified in § 20 Para. 1 No. 4 KFG) is deemed equivalent to a registration if headlights or warning lights with blue light are visibly attached to the motor vehicles in accordance with § 20 Para. 5 KFG. The respective facility must apply in writing to ASFINAG for exemption from the vignette obligation by 30 September of each year for the following year, providing appropriate evidence that the requirements set out in this provision are met and for which motor vehicles the exemption is requested.
- Motor vehicles of fire brigade organisations to which headlights or warning lights with blue light are visibly attached in accordance with § 20 Para. 5 KFG
- Army vehicles (§ 2 para. 1 no. 38 KFG 1967)
- Vehicles that are used within the scope of the agreement among the states party to the North Atlantic Treaty and the other states participating in the Partnership for Peace regarding the status of their forces ("PfP--SOFA"). If non-military motor vehicles are used for these trips, they shall provisionally be subject to the vignette obligation. The toll paid in the course of these trips will be refunded by ASFINAG free of charge. The application for a refund must be submitted by the relevant state authorities once the trips have been completed.

Refund applications must be accompanied by evidence that the toll was paid and submitted directly to ASFINAG Maut Service GmbH (see Appendix 6a).

- Motor vehicles used in the performance of peace-keeping operations within the framework of an international organisation, the Organisation for Security and Cooperation in Europe or the European Union pursuant to a decision taken under the common foreign and security policy. If non-military motor vehicles are used for these trips, they shall provisionally be subject to the vignette obligation. The toll paid in the course of these trips will be refunded by ASFINAG free of charge. The application for a refund must be submitted by the relevant state authorities once the trips have been completed. Refund applications must be accompanied by evidence that the toll was paid and submitted directly to ASFINAG Maut Service GmbH (see Appendix 6a).
- Vehicles belonging to the public security forces, tax authorities, prison services, and foreign security forces in accordance with section 2(3) of the Police Co-operation Act, as well as vehicles belonging to foreign customs and judicial authorities. Confiscated vehicles that use the road network subject to tolls and to which an official tax authority registration number has been attached are not subject to the vignette obligation.
- Vehicles belonging to foreign public emergency services, foreign fire brigades or foreign rescue services. Such motor vehicles shall be exempt from the vignette obligation only if they are fitted with headlamps or warning lights emitting a blue light visibly on the outside and only for the duration of the use of the headlamp or warning light emitting a blue light. On the return journey from an operation in which headlights or warning lights with blue light were used, these vehicles are also exempt from the vignette obligation.

Vehicles that have blue headlights or warning lights visibly attached to the exterior, but are not registered and therefore carry transfer license plates or other equivalent plates and that use the road network subject to tolls are not exempt from the vignette obligation.

Autobahnen- und Schnellstraßen-Finanzierungs-Aktiengesellschaft must provide free vignettes for army vehicles (section 2 sub-paragraph 38 Motor Traffic Act 1967), vehicles belonging to the public security forces, tax authorities, and the prison services that have been allocated special licence plate numbers ('Deckkennzeichen') in accordance with section 48(1) Motor Traffic Act 1967.

In cases of doubt ASFINAG has the right to demand further proof for the above mentioned requirements for an exemption.

1.3.3.2 Time-limited exemptions

1.3.3.2.1 *Exemption in the event of traffic restrictions that cannot be postponed*

In the event of an urgent traffic restriction within the meaning of section 44b(1) of the Road Traffic Act (StVO) on a non-trunk road network, vehicles that are directed by officers of the road inspection authorities, road maintenance units, fire brigade, public breakdown service, or waste disposal companies to use sections of a motorway or expressway as part of the diversion route are not obliged to have a valid vignette on the motorway or expressway. Vehicles without a valid vignette must leave the motorway or expressway at the next possible exit.

1.3.3.2.2 *Exceptions for humanitarian aid transports*

In addition to the above provision, ASFINAG may in accordance with section 5(2) BStMG (Federal Road Toll Acts) and depending on the circumstances, exempt vehicles with a maximum technically permissible laden mass of no more than 3.5 t that are delivering humanitarian aid in the event of emergencies or disasters from the vignette obligation.

An exemption from the vignette obligation for journeys within the context of humanitarian aid transports applies without exception only in the event that there is an occasion within the meaning of Section 5 para. 2 BStMG (Federal Road Toll Acts) and the specific occasion is announced in the Tolling Regulations at this point.

In order to be able to make such a journey without paying the toll (affixing a vignette as defined in item 2 or registering the vehicle licence plate in the toll system as defined in item 3), the exemption request (Appendix 3a) must be completed and duly signed at least 24 hours before using the road network subject to tolls by e-mail ausnahmeantrag@asfinag.at or by fax (+43 1 955 1277) (application available at <https://www.asfinag.at/mautordnung>). The applicant will receive written confirmation. This confirmation must be carried in the vehicle for the duration of the trip that is exempt from the obligation to pay tolls and must be presented upon request as evidence of exemption approval. An exemption from the vignette obligation for journeys within the context of humanitarian aid transports applies to both outward and return journeys.

Currently applicable cases:

The emergency situation due to the armed conflict in Ukraine is considered a case of necessity within the meaning of Section 5 (2) BStMG (Federal Road Toll Acts). The term "humanitarian aid transport" includes journeys for the purpose of transporting goods and merchandise as well as journeys for the purpose of transporting persons who are considered displaced persons within the meaning of the Displaced Persons Ordinance, BGBl II No. 92/2022. The toll exemption is unlimited in time and applies from 1.3.2022.

For humanitarian reasons due to the armed conflict in Ukraine, all motor vehicles with Ukrainian licence plates are exempt from the vignette obligation. This toll exemption is provisionally limited until 30 September 2024 and applies from the date of publication of the Tolling Regulations on the internet at <https://www.asfinag.at/mautordnung>.

1.3.3.2.3 *Exemptions at the request of the Federal Ministry of the Interior in the context of state crisis and disaster control management or international disaster aid*

At the request of the Federal Ministry of the Interior, trips carried out by motor vehicles with a maximum technically permissible laden mass of no more than 3.5 t within the framework of state crisis and disaster protection management or international disaster relief may be exempted from the payment of tolls on a case-by-case basis.

To enable such trips to be made without the obligation to pay the toll (affixing a toll sticker as defined in item 2 or registering the license plate number in the toll system as defined in item 3), the Federal Ministry of the Interior must notify ASFINAG of these trips, listing the license plate number of the motor vehicles concerned and announcing the expected route and the exemption period before using the road network subject to toll payment.

The written confirmation of the Federal Ministry of the Interior (BMI) concerning the concrete exception to the obligation to pay tolls during the toll-free trip must be carried in the affected motor vehicles and presented on request as evidence of the exemption authorisation.

1.4 VIGNETTE PRICES

The vignette prices are set either legally or by decree of the Federal Minister for Climate Protection, Environment, Energy, Mobility, Innovation and Technology in agreement with the Federal Minister of Finance. The valid vignette prices are quoted in Appendix 1 and vary according to the vehicle type and the duration of use. Prices include 20% VAT.

1.5 DURATION OF ENTITLEMENT OF USE

The validity period of the toll sticker and the digital vignette is the same. The validity period of a toll sticker can be visually verified, whereas the validity of a digital vignette can be checked (free of charge) by retrieving the vehicle's license plate number in the vignette registry.

1.5.1 Annual vignette

The annual toll sticker is valid for the year indicated on the toll sticker. Furthermore, it may be used from 1 December of the previous year to 31 January of the following year of the year designated on the toll sticker (see Appendix 1).

When using the digital annual vignette the validity period will be indicated, besides the query of the vignette registry, on the latest valid order confirmation, issued after registering the motor vehicle's licence plate number in the toll system.

1.5.2 Two-month vignette

The two-month vignette entitles the bearer to use the roads for two months, from the first day of validity.

When using a two-month toll sticker the first validity day will be marked by a hole in the appropriate starting day in accordance with the toll sticker samples (see Appendix 1). The hole will be punched by the seller at the toll sticker sales points.

In case of using a two-month digital vignette the validity period will be indicated, besides the query of the vignette registry, on the latest valid order confirmation, generated after registering the motor vehicle's license plate number in the toll system.

This toll sticker expires at the end of the day of the second month that corresponds to the date on which the toll sticker came into effect (= first day of validity) or, if no such date exists in that month, at the end of the last day of the second month (see Appendix 1).

The last possible first validity day of a two-month vignette from the current calendar year is 30 November. Due to the two-month validity period, this two-month vignette may be used until 30 January of the following year. In case a two-month vignette should have its first validity day in December of any calendar year, only a two-month vignette of the following calendar year can be purchased. For possible restrictions on the choice of the first validity day of a digital two-month vignette, see in particular item 3.2.1.1

1.5.3 Ten-day vignette

The ten-day vignette entitles the holder to use the road for ten consecutive calendar days from the first day of validity.

When using a ten-day toll sticker, the first validity day will be marked by a hole in the appropriate starting day in accordance with the toll sticker samples (see Appendix 1). The hole will be punched by the seller at the toll sticker sales point.

In case of using a digital ten-day vignette, the validity period will be indicated, besides the query of the vignette registry, on the latest valid order confirmation generated after registering the vehicle's license plate number in the toll system.

The last possible first validity day of a ten-day vignette is the 30 November. On the basis of the ten-day period of validity, this ten-day vignette may only be used until 9 December of the same calendar year. In case a ten-day vignette has its first validity day in December of any calendar year, only a ten-day vignette of the following calendar year can be purchased. For possible restrictions on the choice of the first validity day of a digital ten-day vignette, see in particular item 3.2.1.1.

1.5.4 One-day vignette

The one-day vignette is only available as a digital vignette and is already available before 1 December 2023 in accordance with Section 33 para. 18 no. 9. However, the first possible day of validity of a digital one-day vignette is 1 December 2023 in accordance with Section 12 para. 5 BStMG (Federal Road Toll Acts).

The digital one-day vignette authorises road use on a freely selectable calendar day (see item 3.2.1.1).

In case of using a digital one-day vignette the validity period will be indicated, besides the query of the vignette registry, on the latest valid order confirmation, generated after registering the vehicle's license plate number in the toll system.

The last validity day in a calendar year from which onwards the one-day vignette is valid is 30 November. In case a one-day vignette has its validity day in December of any calendar year, only a one-day vignette of the following calendar year can be purchased. For possible restrictions on the choice of the first validity day of a one-day vignette, see in particular item 3.2.1.1.

1.6 RELIEF MEASURES

1.6.1 Vignettes free of charge for people with disabilities

Persons with disabilities ("persons entitled to benefits") are entitled to a free digital vignette under the conditions of § 13 BStMG (Federal Road Toll Acts) in conjunction with the Insurance Tax Act of 1953 and the associated ordinance (ANB-V as amended).

For this purpose, the claimant must contact the local registration office responsible for the registration of the motor vehicle.

The examination of the eligibility conditions according to § 13 para. 2 of the BStMG (Federal Road Toll Acts) is carried out by the municipal body of the insurer entitled to operate the motor vehicle liability insurance ("municipal body").

After successfully passing the eligibility requirements inspection, the municipal body shall arrange for the registration of the vehicle license plate of the exempted motor vehicle in the ASFINAG toll system. The vehicle of the claimant entitled to benefits remains exempted if the vehicle license plate is changed.

At the time of registration in the ASFINAG toll system, the entitled party will receive a free digital vignette.

A query of the vehicle license plate in the vignette registry (see item 1) provides information as to whether an exempted vehicle has a valid digital vignette and for what period it is valid. The digital vignette is displayed in the vignette registry in the respective year as a digital annual vignette (see item 1.5.1 "Duration of the entitlement to use").

1.6.2 Right to reimbursement of vignettes issued for disabled persons

Pursuant to § 13 para. 7 of the BStMG (Federal Road Toll Acts), ASFINAG shall, upon request, reimburse to someone who is entitled to benefits the price of one or several annual vignettes which he or she has demonstrably acquired for the motor vehicle registered in his or her name from the calendar year in which one of the aforementioned entries in the claimant's disabled person's pass was valid.

The price of an annual vignette shall be refunded for each person entitled to benefits for each vignette year.

To apply for a refund, the claimant must submit the following documents to ASFINAG Maut Service GmbH (see information under item 1.13):

- Copy of the vehicle registration certificate of the disabled pass holder
- Proof of residence or usual abode in Germany
- Copy of the disabled person's pass in which the unreasonableness of using public transport or blindness is documented
- Invoice for the previously purchased annual toll sticker or its allonge or the product ID of the digital annual vignette.

In cases of doubt, ASFINAG shall be entitled to demand further evidence (e.g. confirmation from the Federal Office for Social Affairs and Disability that no vignette has been provided free of charge).

1.7 OBLIGATIONS

Before using the road network subject to tolls with a vehicle that is liable for the toll, every driver has to make sure that, for the period of the intended use of the road network subject to tolls, the time-based toll has properly been paid for (in advance). This includes checking if the toll has properly been paid by using the correct type of vignette, according to the vehicle type.

In case of using a toll sticker to pay the toll, the bearer has to visually check if the toll sticker is attached in the correct location, it is attached properly (if carrying an unattached toll sticker is not explicitly permitted, see item 2.2.2), and that it is "intact" as well as visible and verifiable.

In case of using a digital vignette, the vehicle registration number in the vignette registry (see item 1) must be queried immediately before the road network subject to tolls is used to determine

whether a vehicle has a valid digital vignette and for which time period it is valid (or they are valid if the vehicle has several digital vignettes).

If the transitional regulation of § 33 para. 18 Z 8 BStMG (Federal Road Toll Acts) (see item 1.2.) is utilised, the driver must provide proof of fulfilment of the requirements and send it to tzgm@asfinag.at.

Furthermore, every vehicle driver has to – according to section 102(2) KFG – make sure that the official license plate number of the vehicle that is liable for toll, is completely and permanently visible during the journey and has not been covered by dirt or snow, respectively damaged deformed in such a way that it is illegible.

If the time-based toll has not been properly paid in advance, the driver must refrain from intending to use the road network subject to tolls. Otherwise, the offence of toll evasion as defined in item 1.9 shall be deemed to have occurred.

1.8 MONITORING COMPLIANCE WITH THE VIGNETTE OBLIGATION

1.8.1 Inspection by road inspection authorities and toll enforcement officers

Compliance with payment of the time-based toll is monitored by the toll enforcement officers in accordance with §§ 17ff BStMG (Federal Road Toll Acts). The toll enforcement officers are organs of public supervision. They are appointed and sworn in in accordance with the provisions of Section 17 (2) BStMG (Federal Road Toll Acts). In the performance of their duties the toll enforcement officers must carry with them the identification document described below and present it to the parties concerned upon request.

The ID card for toll enforcement officers, which confirms their official capacity, is the size of a cheque card, is printed on both sides and contains the following information in particular: photograph, name and service number of the toll enforcement officer (see Figure 6):



Figure 6

The toll enforcement officers' vehicles are public security force enforcement vehicles that comply with section 20(1)(4) lit.a of the Motor Vehicle Act 1967. These vehicles are silver-grey operational vehicles that are equipped with flashing blue lights and a siren. Furthermore, they are labelled with the following inscriptions: "ASFINAG", "Toll monitoring" and "Service and control service of ASFINAG" (see Figure 7):



Figure 7

For the purposes of checking correct payment of the toll as well as the time-based toll and section toll, the toll enforcement officers are empowered, among other things, to request drivers to stop by using clearly visible or audible signs, to stop them, to check the affixing of the toll sticker or the registration of the motor vehicle license plate in the toll system, to establish the identity of the driver and of the holder of the registration certificate, the motor vehicle (in particular the vehicle registration certificate), – in the case of journeys with test or transfer license plates within the meaning of item 1.2 – to check evidence of the vehicle's tare weight (in particular a copy of the type certificate), and to ask drivers to pay any substitute toll due.



Figure 8

Furthermore, the toll enforcement authorities are authorised to divert motor vehicles to the toll checkpoints with the aid of automatic traffic guidance systems for the purpose of checking for proper payment of the toll and to carry out traffic surveys, currently A 1 Eberstalzell, A 1 Haag, A 1 Walserberg, A 2 Arnoldstein, A 2 Arnwiesen, A 2 Haimburg, A 2 Ilztal, A 6 Kittsee, A 4 Bruck/Leitha, A 4 Nickelsdorf, A 4 Gols, A 4 Zurndorf, A 5 Schrick, A 8 Kematen, A 8 Suben, A 9 Liesingau, A 9 Liezen, A 9 Schoberpaß, A 9 Straß, A 9 Trieben, A 9 Übelbach, A 9 Windischgarsten, A 10 Hoher Göll, A 10 Kellerberg, A 11 Rosegg, A 11 Karawankentunnel, A 12 Kontrollbucht Roppener Tunnel Ostportal, A 12 Kontrollbucht Zirl Ost, A 12 junction Wörgl-Ost, A 14 Hörbranz, A 14 Nüziders, S 4 Pöttsching, S 3 Göllersdorf, S 16 Kettenanlageplatz Bings, S 31 Hirm Nord, S 31 Hirm Süd and S 37 Maria Saal.

Additionally, toll enforcement officers may also monitor the correct payment of tolls and conduct traffic surveys at border crossings and junctions.

If no substitute toll is paid and if prosecution or enforcement of the penalty appears to be impossible or considerably more difficult, toll enforcement officers are authorized pursuant to § 27 BStMG (Federal Road Toll Acts) to collect a provisional security deposit or, as long as the provisional security deposit is not paid, to order the interruption of the trip pursuant to § 28 BStMG (Federal Road Toll Acts) and to prevent its continuation by taking suitable precautions (removal of

the vehicle keys and vehicle documents, installation of technical locks on the vehicle, parking at a suitable location, etc.).

1.8.1.1 Inspection of the moving traffic (on inspection areas and junctions)

Whether the toll has been paid or not will be examined by the toll enforcement officers by a visual inspection (toll sticker) as well as by the help of technical devices (digital vignette) on the spot.

For that particular purpose a camera will be placed at the roadside (on the access or exit of a motorway or expressway on which toll is being collected or on a toll control area) and adjusted towards the driving lane. The motor vehicle license plate numbers of all passing vehicles will be captured to verify whether they have a valid digital vignette or not.

The result of this examination will be indicated to the toll enforcement officer via a mobile display device. Subsequently, the toll enforcement officer may visually verify if the motor vehicle has a valid toll sticker properly attached to the vehicle.

1.8.1.2 Inspection of the stationary traffic

Besides the inspection of the moving traffic, there are also mobile inspections of the stationary traffic (e.g. on resting areas). The toll enforcement officer visually examines whether a toll sticker has been attached properly onto the vehicle. If this is not the case, the toll enforcement officer will verify if a digital vignette has been acquired for the vehicle.

1.8.2 Automatic vignette monitoring

The automatic monitoring of vignettes (AVK) is carried out in accordance with the requirements of the BStMG (Federal Road Toll Acts) and is registered with the Data Processing Register. It is a mobile electronic system that selectively monitors whether tolls have been correctly paid. The AVK is used at constantly changing locations across Austria for a limited period at each location.

The AVK uses special software to check the windscreens of passing vehicles concerning attached toll stickers respectively the passing vehicle's license plate numbers, to examine whether the motor vehicle license plate number has been registered in the toll system. The system is capable of identifying the validity of vignettes and only saves images of vehicles which are suspected of not having paid the time-based toll properly (suspicion of toll evasion in accordance with section 20 BStMG (Federal Road Toll Acts), see also item 1.9 below). Cases not considered suspicious will not be stored for statistical or other purposes once the monitoring process is complete.

The suspicious case stored in relation to the automatic monitoring will retrospectively be checked and verified by caseworkers of ASFINAG Maut Service GmbH. Manual processing involves performing several checks. If the suspicious case is confirmed, proceedings to ensure payment of a substitute toll will be initiated.

1.9 TOLL EVASION

1.9.1 Penalties for toll evasion

It is prohibited to use the road network subject to tolls with motor vehicles subject to tolls within the meaning of these Tolling Regulations without a valid vignette properly affixed, properly carried

in accordance with item 2.2.2 of the Tolling Regulations Part A I or without having properly registered the vehicle licence plate in the toll system. In accordance with section 20(1) BStMG (Federal Road Toll Acts), drivers who violate this prohibition are in breach of an administrative rule and may be fined between EUR 300.00 and EUR 3,000.00 by the local district administrative authorities.

1.9.2 Non-imposition of a penalty

A penalty will not be imposed if a substitute toll - as described below - is paid. Any substitute toll duly paid in accordance with § 19 BStMG (Federal Road Toll Acts) cannot be reclaimed (§ 20 para 6 BStMG (Federal Road Toll Acts)).

1.9.3 Substitute toll

1.9.3.1 *Method of payment*

The substitute toll may not be paid in instalments. If instalments are received, they will be credited to the payer's account minus a processing fee of EUR 15.00 (including 20% VAT). This also applies to late payments after filing a report with the competent district administrative authority, payments without stating the correct identification number, which is listed as the payment reference, as well as payments to an account other than the one disclosed on the copy of the request for payment of a substitute toll or an information letter pursuant to section 30b para. 1 BStMG (Federal Road Toll Acts). In the event of overpayments up to and including EUR 5.00, no money will be credited to the payer's account (otherwise the entire amount will be credited to the payer's account).

1.9.3.1.1 *Request by toll enforcement officers*

Toll enforcement officers are authorized to verbally request the motor vehicle driver (if necessary also as representative of the registration holder in accordance with § 19 para. 5 BStMG (Federal Road Toll Acts)) to pay a substitute toll. The substitute toll shall be paid immediately upon request by the toll enforcement officer in cash or by the payment method specified in Appendix 2 of the Tolling Regulations. The vehicle driver shall be issued with a confirmation of the payment made.

1.9.3.1.2 *Discovery of a violation in the absence of the driver*

If a violation is discovered by toll enforcement officers during the course of their work without the driver being apprehended in person (e.g. because the driver is not at the vehicle), a written request to pay the substitute toll may be left at the vehicle. In addition to the amount of the substitute toll to be paid, the written request shall contain, among other things, an identification number, which is listed as the payment reference, and the claimant's bank details.

The substitute toll shall be paid to the account specified in the request for payment, indicating the identification number, which is listed as the payment reference, specified in the request. The request for payment of the substitute toll is complied with if it is credited to the specified account within two weeks of the deposit and the transfer order contains the correct, complete and automatically readable identification number, which is listed as the payment reference.

1.9.3.1.3 Retrospective summons process

If a violation is discovered by means of automatic monitoring of vignettes without the driver being apprehended in person, the/a registration certificate holder may receive a written request to pay the substitute toll. In cross-border procedures, the request for payment of the substitute toll is made in the form of an information letter in accordance with section 30b para. 1 of the BStMG (Federal Road Toll Acts), which is listed as a template in Appendix 7 to the Tolling Regulations.

In addition to the amount of the substitute toll to be paid, the written request shall contain, among other things, an identification number, which is listed as the payment reference, and the claimant’s bank details.

The substitute toll must be transferred to the account specified in the request for payment or the information letter pursuant to Section 30b (1) BStMG (Federal Road Toll Acts), stating the identification number specified in the request, which is given as the payment reference. The request for payment of the substitute toll shall be complied with if it is credited to the specified account within four weeks of the issuance of the request or the information letter pursuant to section 30b para. 1 BStMG (Federal Road Toll Acts) and the transfer order contains the computer-readable, complete and correct identification number, which is listed as the payment reference.

1.9.3.2 Substitute toll rate

The substitute toll rates (including 20% VAT) for non-payment of the time-based toll are given below:

Vehicle category	Substitute toll rate
A (single-track motor vehicles)	EUR 65.00
B (multi-track vehicles with a maximum technically permissible laden mass of up to 3.5 t)	EUR 120.00

If a toll sticker has not been attached properly to the vehicle (see item 2.2.) and has been manipulated by chemical and technical means in such a way that the toll sticker is prevented from self-destruction upon removal or multiple use cannot be excluded, the price of the substitute toll will be doubled for each category (see table above).

If the re-registration of the digital annual vignette has been omitted before using the road network subject to tolls with the motor vehicle liable to pay the toll, the following applies:

If it is established that the toll has not been paid properly and the vehicle driver is requested in writing by toll enforcement officers or the vehicle registration holder is requested in writing by ASFINAG to pay the substitute toll, the vehicle driver/registration holder can contact the ASFINAG Service Center after receiving the request to pay a substitute toll or an information letter pursuant to Section 30b para. 1 BStMG (Federal Road Toll Acts). The ASFINAG Service Center will carry out the re-registration to the new vehicle licence plate to be registered upon presentation of suitable evidence if the requirements for re-registration of the digital annual vignette pursuant to item 3.6 are met.

In this case, with the proper payment of the substitute toll, the time-based toll for the motor vehicle license plate number, which has been newly assigned to the registration holder, will be paid retrospectively for the period between the date of the first breach of an administrative rule with the newly assigned motor vehicle license plate number and the date of the re-registration. The amount of EUR 18.00 for the re-registration (see item 3.6) is not payable in this case and/or will be reimbursed. If the road network subject to tolls has been used before the start of validity of the digital annual vignette, the following applies:

If it is established that the toll has not been properly paid and the driver of the motor vehicle is requested in writing to pay the substitute toll by toll enforcement officers or the holder of the registration certificate by ASFINAG, the driver of the motor vehicle/holder of the registration certificate may, after receiving the request for payment of a substitute toll or an information letter in accordance with section 30b para. 1 BStMG (Federal Road Toll Acts), contact the ASFINAG Service Center and invoke the fact that the road network subject to tolls with the motor vehicle license plate number concerned was used in the period between the purchase of the digital annual vignette and the start of its validity.

In this case the time-based toll for this time period will be paid retrospectively with the proper payment of the substitute toll.

If the use of the road network subject to tolls with a motor vehicle with an obligation to pay tolls without a valid vignette is detected several times within 30 days, ASFINAG will issue requests for payment of a substitute toll or send information letters in accordance with section 30b para. 1 BStMG (Federal Road Toll Acts) for a maximum of three cases of toll evasion. No substitute toll is payable for any additional toll evasion cases and these cases will not be reported to the local district administrative authorities.

1.9.3.3 Continued journey

Payment of the substitute toll authorises the driver of the motor vehicle to use the toll (vignette) road network on the day the driver was apprehended by a toll enforcement officer, on the day on which an enforcement officer has left a written request for payment of the substitute toll on their motor vehicle, on the day on which the breach of an administrative rule has been determined by automatic monitoring and on the following calendar day.

Either the receipt issued after the driver was apprehended or the payment slip attached to the written request to pay the substitute toll are considered to be proof of payment of the substitute toll. In the event of non-compliance, the offence of toll evasion shall be committed. Drivers who refuse to pay the toll after being apprehended are obliged to leave the toll road immediately at the next possible exit.

Upon leaving the vehicle, the driver must ensure that the receipt or the payment slip is placed inside the windscreen in such a way that the entitlement of use (especially the location, date, and time of issue and the vehicle's license plate number) can easily be seen and inspected from outside the vehicle.

Failure to comply with this provision constitutes a toll evasion offence.

1.9.3.4 *Payment of the substitute toll*

Substitute tolls must be paid in Euros. Information on which payment methods and means are authorised for payment of the substitute toll to toll enforcement officers is regulated in Appendix 2 (available at <https://www.asfinag.at/mautordnung>) and can be obtained from the ASFINAG Service Center (see item 1.13).

1.10 VIOLATION OF THE OBLIGATION TO STOP

Motor vehicle drivers who, contrary to § 18 para. 2 BStMG (Federal Road Toll Acts), do not comply with a request to stop a body mentioned in item 1.8.1, are committing an administrative offence pursuant to § 21 BStMG (Federal Road Toll Acts) and are liable to fines of up to EUR 3,000.00.

1.11 DATA PROTECTION AND DATA SECURITY

ASFINAG is entitled pursuant to § 16a BStMG (Federal Road Toll Acts) to process the personal data required for toll collection, toll collection and the prosecution of toll evasion with the aid of automation. Furthermore, ASFINAG is also entitled to process personal data which is required for the vignette registry (see item 1) in accordance with section 16b BStMG (Federal Road Toll Acts).

To verify if the toll has been paid properly and to trace toll evasion, in accordance with section 19a BStMG (Federal Road Toll Acts), ASFINAG is entitled to use technical equipment. For the description of how the technical equipment is working see item 1.8.1 and 1.8.2. The image data and the license plate number and control data obtained from it may be processed for the purposes of collecting the toll, requesting payment of a substitute toll or the information letter pursuant to section 30b para. 1 of the BStMG (Federal Road Toll Acts) and prosecuting toll evasion.

More detailed explanations of the data protection principles and information on the rights of data subjects are available online at <https://www.asfinag.at/privacy>.

1.12 JURISDICTION AND APPLICABLE LAW

The exclusive place of jurisdiction for all claims against ASFINAG under civil law arising out of these Tolling Regulations and/or the use of the road network subject to tolls shall be the court that has jurisdiction as regards such matters for the third district in Vienna. Only Austrian law applies, excluding the conflict of laws rules of private international law.

1.13 RESPONSIBILITY AND CUSTOMER SERVICE (ASFINAG SERVICE CENTER)

All queries or applications for refunds for vignettes should be addressed to the ASFINAG Service Center of ASFINAG Maut Service GmbH:

ASFINAG Maut Service GmbH
Alpenstraße 99
5020 Salzburg, Austria
Austria

Telephone number: 0800 400 12 400 (free of charge from Austria and Germany)
Telephone number: +43 1 955 1266
Fax number: +43 1 955 1277
E-mail /website: info@asfinag.at / <https://www.asfinag.at>

2 FURTHER REGULATIONS WHEN USING A TOLL STICKER

In addition to the general regulations the following regulations apply in case a toll sticker is used.

2.1 SALE OR DISTRIBUTION OF THE TOLL STICKER

Toll stickers can be purchased at points of sale marked with the toll sticker symbol (see Appendix 1).

The price of purchased toll stickers cannot be refunded or replaced.

2.2 ATTACHING THE TOLL STICKER

2.2.1 Where and how to attach the toll sticker

A valid adhesive vignette corresponding to the respective vehicle category must be properly affixed to every motor vehicle subject to the toll whose licence plate number has not been registered in the toll system (taking into account item 2.2.2 Tolling Regulations Part A I) before using the toll road network.

A toll sticker is only deemed to have been properly affixed if it has been affixed

- in such a way that it has been completely detached from the backing film,
- using the original vignette adhesive,
- completely and without any damage,
- in such a way that it is clearly visible and easy to check,
- without any additional aids.

For multi-track motor vehicles, the toll sticker must be affixed directly onto the inside of the windscreen in such a way that it is easily visible and verifiable from the front and outside (e.g. no sticking behind a dark tint strip, no sticking to parts of the windscreen that are curved backwards in the case of panorama windows, no sticking to a side window).

On a motorcycle, toll stickers must be affixed visibly and verifiable on a part of the motorcycle that is either difficult or impossible to remove.

Ten-day toll stickers and two-month toll stickers are furthermore only valid if they have been validated by correctly, completely and clearly visible punching holes in the appropriate calendar day and month.

Any other type of attachment (e.g. use of aids (e.g. adhesive strips), other types of fixation (e.g. parking ticket holders etc.), sticking an (additional) protective film over the toll sticker, incomplete detachment from the carrier film ("X" on the carrier film is visible) or incomplete attachment of the vignette) as well as any multiple use of the toll sticker other than that permitted in these Tolling Regulations is not permitted, forfeits evidence of proper toll payment and may constitute a toll evasion offence (see item 1.9).

Drivers are advised to observe the recommendations on how to attach the toll sticker printed on the back of the toll sticker.

Removing a toll sticker that has already been affixed triggers security features (see Appendix 1) and the vignette loses its validity.

Chemical or technical manipulation of the original toll sticker in such a way that its self-destruction effect is prevented when the toll sticker is removed and multiple use cannot be ruled out is not permitted and may constitute a toll evasion offence.

In the interest of road safety and in order to ensure effective and user-friendly verification of time-based toll payment, a maximum of one additional toll sticker should, if possible, be attached to the vehicle in addition to the valid toll sticker.

2.2.2 Permissibility of carrying an unattached toll sticker in the vehicle

Drivers of approved vehicle models without windscreens are permitted to carry an unattached toll sticker in the vehicle. The same applies if windscreens may not be brought into contact with the toll sticker due to a technical certificate issued by the manufacturer, provided that a vehicle-related release letter from ASFINAG Maut Service GmbH (see information under item 1.13) is carried along in the original.

In the case of vehicles that carry transfer license plates, drivers are permitted to carry an unattached, properly stamped two-month toll sticker in the vehicle instead of directly attaching the toll sticker to the vehicle (see item 1.5.2).

Before leaving a parked vehicle (e.g. at service areas on the road network subject to tolls) the driver must ensure that the toll sticker is clearly visible and verifiable from outside the vehicle. Failure to comply with this provision constitutes a toll evasion offence (see item 1.9).

2.3 TOLL STICKER REPLACEMENT

In the event that the windscreen on which the adhesive annual toll sticker is affixed is destroyed and replaced, ASFINAG Maut Service GmbH (see item 1.13) will issue a replacement vignette free of charge, provided that no claim is made against third parties. The following evidence must be presented when making use of the services:

- a copy of the vehicle registration certificate
- a copy of the invoice for the replaced wind screen issued by the garage that carried out the repairs (in the case of company cars, the name of the driver must also be given);
- the detached toll sticker;
- a toll sticker replacement form (filled out and signed).

If a vehicle to which an annual toll sticker is attached is damaged to such an extent as a result of an accident or force majeure that the vehicle is no longer roadworthy (i.e. the vehicle is a technical write-off), the owner of the annual toll sticker is entitled to apply for a free replacement vignette from ASFINAG Maut Service GmbH as long as there are no claims against third parties.

The following evidence must be presented when making use of the services:

- the original removed annual toll sticker or a sufficient part of the remaining toll sticker;
- confirmation from a garage or automobile club that the vehicle is a technical write-off or confirmation that it has been scrapped or handed over to a third party for scrapping.
- registration confirmation from the motor vehicle registration office, and
- brief description of the events that occurred.

In cases of doubt, ASFINAG is entitled to request photographic evidence of the vehicle in question.

In cases where the toll sticker has been rendered invalid or destroyed in circumstances that fall within the sphere of responsibility of the toll sticker producer, ASFINAG Maut Service GmbH (see information in item 1.13) or its authorised agents shall provide a replacement vignette free of charge.

If the applicant wishes to register their motor vehicle license plate number in the toll system (digital vignette) instead of a replacement of the toll sticker, they should request that on the toll sticker replacement form and attach the vehicle registration certificate.

More detailed explanations and the form depending on the circumstances (replacement vignette, write-off) are available on the internet at <https://www.asfinag.at/klebevignette/>. It is impermissible for a driver to use toll roads until such time as the replacement toll sticker has been received.

No replacements are provided for toll stickers that are destroyed in other circumstances (e.g. the removal of a vignette that has already been attached).

3 FURTHER REGULATIONS WHEN USING A DIGITAL VIGNETTE

3.1 AVAILABILITY OF THE DIGITAL VIGNETTE

As an alternative to the toll sticker, the time-based toll can also be paid by registering the number plate of the vehicle in the ASFINAG toll system (digital vignette).

From the time of validity of the digital vignette (see in detail item 3.2), the toll for the indicated license plate number is thus properly paid and entitles the digital vignette to use federal roads in accordance with sections 1 para. 1 and 11 para. 1 BStMG (Federal Road Toll Acts).

3.2 OBTAINING THE DIGITAL VIGNETTE

The following distribution channels are provided to register the vehicle's license plate (obtaining the digital vignette) in ASFINAG's toll system (see also Appendix 1):

3.2.1 Procurement of the digital vignette via the ASFINAG toll shop and authorised online distribution partners

The digital vignette can be obtained in the ASFINAG toll shop or from an authorised online distribution partner with the ASFINAG app from within Austria, the European Union as well as in the EEA states and Switzerland.

A limited range of products is available from authorised online distribution partners. Further information on authorised online distribution partners is available on the internet at <https://www.asfinag.at/vertriebsstellen/>.

3.2.1.1 *Start of validity*

3.2.1.1.1 *Annual vignette and two-month vignette*

If the digital annual vignette or the digital two-month vignette is purchased by consumers by means of distance selling, i.e. via the ASFINAG toll shop, the first day of validity is the 18th day after procurement at the earliest. As an example:

A digital annual vignette is purchased in the ASFINAG toll shop on 15 January. The first day of validity is therefore 2 February at the earliest and the right to use the motorways and expressways only exists from this day onwards.

A different, later date for the first day of validity (in the above example, 5 April) can be selected manually when purchasing digital two-month vignettes.

The right to use motorways and expressways is valid from the selected first day of validity, but at the earliest from the 18th day after obtainment.

The duration of entitlement of use is regulated in item 1.5.

With regard to the acquisition of the digital subscription service and the associated specific features please see item 3.2.5.2. and 3.2.6 on the digital annual vignette.

3.2.1.1.2 *Ten-day vignette*

If the digital ten-day vignette is purchased by consumers by means of distance selling, i.e. via the ASFINAG toll shop or an authorised online distribution partner, early fulfilment of the contract can be expressly requested.

Here are some examples:

A digital ten-day vignette is purchased in the ASFINAG toll shop on 15 January and early fulfilment of the contract is expressly requested. 15 January can be selected as the first day of validity. In this case, the digital ten-day vignette is valid from the time of purchase until the end of the tenth calendar day (e.g. 15 January, 07:22 to 24 January, 23:59:59).

A different, later date for the first validity day can be selected when purchasing digital ten-day vignettes. The entitlement to use motorways and expressways is valid from the selected first day of validity (e.g. 20.1., 00:00 to 29.1., 23:59:59).

The duration of entitlement of use is regulated in item 1.5.

3.2.1.1.3 *One-day vignette*

If the digital one-day vignette is purchased by consumers by means of distance selling, i.e. via the ASFINAG toll shop or an authorised online distribution partner, early fulfilment of the contract can be expressly requested.

Here are some examples:

A digital one-day vignette is purchased in the ASFINAG toll shop on 15 January and early fulfilment of the contract is expressly requested. 15 January can be selected as the first possible day of validity. In this case, the digital one-day vignette is valid from the time of purchase until the end of this calendar day (e.g. 15 January, 07:22 to 15 January, 23:59:59).

A different, later date for the validity day can be selected when purchasing digital one-day vignettes. The entitlement to use motorways and expressways is valid from the selected day of validity (e.g. 20 January, 0:00 to 20 January, 23:59:59).

The duration of entitlement of use is regulated in item 1.5.

3.2.1.2 Required details

To purchase a digital vignette via the ASFINAG toll shop or authorised online distribution partners, the following data must be provided:

- The vehicle type,
- The vehicle's license plate number that shall be registered in the ASFINAG toll system as well as the country of registration of the particular vehicle
- Data relevant for the cashless purchase (e.g. credit card data, etc.)
- A valid e-mail address (for the purpose of sending an order confirmation, the receipt, as well as the terms of use)

The order confirmation must be checked for the correctness of the data (especially with regard to the registered motor vehicle license plate number and the validity period of the digital vignette).

For later re-registrations of the digital vignette via the ASFINAG toll shop under "My Account" (see item 3.6 and 3.2.4) the product ID is needed, which serves also as an identification and is displayed on the order confirmation. The order confirmation should therefore be kept for the duration of the validity of the digital vignette.

3.2.2 Purchase of the digital vignette at an ASFINAG vending machine

The digital vignette can also be obtained at ASFINAG vending machines. They are freely accessible. Further information on the locations of the ASFINAG vending machines is available on the internet at <https://www.asfinag.at/vertriebsstellen/>.

3.2.2.1 Start of validity

If a digital annual vignette is purchased at an ASFINAG vending machine, it is valid immediately. If a digital two-month, ten-day and one-day vignette is purchased at an ASFINAG vending machine, the first validity day can be freely selected. Please refer to items 1.5 and 3.2.1. for the duration of the user authorization and the last possible first validity day.

The right to use motorways and expressways is valid from the selected first day of validity, but at the earliest from the time of procurement.

3.2.2.2 Required details

To purchase a digital vignette at an ASFINAG vending machine, the motor vehicle license plate number, which should be registered in the toll system of ASFINAG, as well as the country of registration of the particular license plate and the vehicle type, have to be provided.

The confirmation of registration of the motor vehicle license plate number in ASFINAG's toll system (order confirmation) and the invoice will be printed out at an ASFINAG vending machine. The order confirmation must be checked for the correctness of the data (especially with regard to the registered motor vehicle license plate number and the validity period of the digital vignette).

For subsequent changes and re-registrations of the digital vignette in the personal user account (see items 3.6 and 3.2.5), the product ID stated on the order confirmation is required as identification. The order confirmation should therefore be kept for the duration of the validity of the digital vignette.

3.2.3 Procurement of the digital vignette at ASFINAG toll stations and points of sale

The digital vignette can also be obtained from ASFINAG toll stations and selected points of sale. Further information on the points of sale is available on the internet at <https://www.asfinag.at/vertriebsstellen/>.

3.2.3.1 *Start of validity*

If a digital annual vignette is purchased at an ASFINAG toll station or point of sale, it is valid immediately. If a digital two-month, ten-day and one-day vignette is purchased from an ASFINAG toll station or point of sale, the first validity day can be freely selected. Please refer to items 1.5 and 3.2.1. for the duration of the user authorization and the last possible first validity day.

The right to use motorways and expressways is valid from the selected first day of validity, but at the earliest from the time of procurement.

3.2.3.2 *Required details*

In order to obtain a digital vignette at a point of sale, the vehicle license plate number to be registered in the ASFINAG toll system, including the country of registration of the vehicle license plate number, as well as the vehicle type must be indicated and the corresponding registration certificate must be inspected at the request of the point of sale to check the plausibility of the information.

The confirmation of registration of the motor vehicle license plate number in ASFINAG's toll system (order confirmation) and the invoice will be printed out at the point of sale. The order confirmation must be checked for the correctness of the data (especially with regard to the registered motor vehicle license plate number and the validity period of the digital vignette). Any need for correction must be reported immediately at the point of sale.

For subsequent changes and re-registrations of the digital vignette in the personal user account (see items 3.6 and 3.2.5), the product ID stated on the order confirmation is required as identification. The order confirmation should therefore be kept for the duration of the validity of the digital vignette.

3.2.4 Means of payment

The digital vignette can only be paid for in the ASFINAG toll shop and at ASFINAG vending machines in euros (EUR). Information on which payment methods or means are permitted in the ASFINAG toll shop and at ASFINAG vending machines is contained in Appendix 2) and is available from the ASFINAG Service Center (see item 1.13).

The means of payment accepted at a point of sale may vary depending on the point of sale and should be enquired from them.

3.2.5 Further Services

3.2.5.1 General services

In the toll shop, it is possible to create a personal user account ("My Account") at any time (i.e. even after completion of the purchase process) by entering access data.

The following services are provided after creating a personal user account and logging in to the ASFINAG toll shop:

- administration of personal data
- administration of vehicles' license plate numbers
- Assignment of previously purchased digital vignettes to the personal user account based on the product ID (except for digital vignettes purchased via authorised online distribution partners)
- administration of digital vignettes that have already been obtained
- reprints of receipts
- Procuring and managing a digital subscription

3.2.5.2 Digital subscription in the personal user account ("My Account")

A digital subscription – a subscription for an indefinite period for acquiring the digital annual vignette in subsequent years – can be taken out, managed (for example keeping credit card details up to date) and cancelled in the ASFINAG toll shop.

The following applies for this:

- Validity: The regulations regarding the start of validity of the digital annual vignette in 3.2.1.1 for consumers and in 3.4 for entrepreneurs apply accordingly to the initial purchase of a digital annual vignette and the acquisition of the digital subscription (= initial acquisition).
- Right of withdrawal: On initial acquisition of the digital subscription, consumers are entitled to withdraw in accordance with 3.3. This right of withdrawal no longer applies, however, with regard to subsequent payments as part of the digital subscription.
- Information to the customer: In order to obtain the digital subscription, providing an e-mail address is required. At least 20 days before payment is collected, the customer receives information, particularly on the date of the upcoming collection of payment (collection of the acquisition price of the annual vignette), the amount to be collected and the last possible date by which cancellation of the digital subscription for subsequent payments is possible. This e-mail address is also used to inform the customer whether collection of payment was successful.
 - *Successful debit*: Following successful collection and thus the acquisition of a digital annual vignette, the customer is informed via the e-mail address specified by the customer and sent the order confirmation and invoice for the transaction. In this case the digital annual vignette is valid as from collection of the acquisition price.
 - *Unsuccessful debit*: The customer is also informed about this via an e-mail to the e-mail address specified by them. If collection is not possible (for example because the credit card specified is no longer valid), this counts as timely cancellation of the

digital subscription. In this case, the customer must ensure that the toll is duly paid at the time that the roads for which a vignette is required are used. All sales channels for both the toll sticker and the digital vignette are available to the customer for this.

- Cancellation of the digital subscription: Cancellation of the digital subscription can be made at any time only in the personal user account ("My Account") without giving reasons.
- Means of payment: The possible means of payment for the digital subscription are listed in Appendix 2.
- Required data: In addition to the information required to obtain a digital vignette (see item 3.2.1.2), it is necessary to create a personal user account (My Account) to obtain the digital subscription. Furthermore, the payment details for collecting subsequent payments must be entered and kept up to date.

3.2.6 Terms of use

Further information on obtaining the digital vignette via the ASFINAG toll shop, obtaining the digital subscription, the therefore required details and steps as well as on additional services, is available in the terms of use, which can be retrieved at <https://shop.asfinag.at>.

In addition, upon request, the current Tolling Regulations and the data privacy policy (<https://www.asfinag.at/privacy>) may be inspected at points of sale at any time.

3.3 RIGHT OF WITHDRAWAL

If the digital vignette has been purchased by a consumer by means of distance communication from the ASFINAG toll shop or an authorised online distribution partner, the consumer can withdraw from the purchase without stating any particular reason, within 14 calendar days from the day on which the digital vignette has been bought.

If early fulfilment of the contract was expressly requested when procuring a digital ten-day vignette in the ASFINAG toll shop or from an authorised online distribution partner, a pro rata fee must be paid in the event of cancellation. Once the validity of the digital ten-day vignette has expired, there is no right of withdrawal.

If early fulfilment of the contract was expressly requested when procuring a digital one-day vignette in the ASFINAG toll shop or from an authorised online distribution partner, there is no longer a right of withdrawal from the start of validity.

In order to exercise the right of withdrawal, ASFINAG must be informed of the decision to withdraw from the procurement by means of a clear declaration, if the digital vignette was procured from the ASFINAG toll shop. If the digital vignette was purchased via an authorised online distribution partner, the latter must be informed of the decision to withdraw from procurement by means of an unambiguous declaration. The withdrawal period shall be respected when the withdrawal notice is sent within the deadline.

There is no right of withdrawal in the event of purchase from a point of sale or an ASFINAG vending machine. This also applies if a digital annual vignette has been obtained as a subsequent purchase via a digital subscription.

More detailed information on the declaration of withdrawal as well as on the refund of payments made is available in the terms of use on the internet at <https://shop.asfinag.at>.

3.4 SPECIFICS FOR ENTREPRENEURS CONCERNING THE PURCHASE OF A DIGITAL VIGNETTE

If an entrepreneur purchases a digital vignette or the digital subscription within their work as an entrepreneur, the following regulations apply:

When obtaining a digital vignette and/or a digital subscription from the ASFINAG toll shop, an entrepreneur needs to confirm their entrepreneurial status as well as the purchase of the digital vignette and/or the digital subscription within their work as an entrepreneur. In this case there is no right of withdrawal and the day of purchase of the digital vignette can be chosen as the first day of validity.

In addition to the details for the purchase of the digital vignette mentioned in item 3.2.1.2, the invoice recipient's details can and must be provided if the amount succeeds EUR 400 (gross).

3.5 POSSIBLE CHANGES BEFORE THE BEGINNING OF VALIDITY

If the validity of a digital vignette has not started yet, the motor vehicle's license plate number and the country of registration registered in the toll system can be changed. Moreover, in case of digital two-month or ten-day or one-day vignettes the first day of validity can only be changed under the following conditions:

- If the digital two-month vignette was purchased from the ASFINAG toll shop, the first day of validity must not be before midnight on the 18th day, 0:00 a.m. after procurement.
Example: A digital two-month vignette was procured in the ASFINAG toll shop on 15 January. The earliest possible start of validity is therefore midnight on 2 February.
- The first day of validity may not be changed to a day in the past – at the time of the change
Example: A digital ten-day vignette with start of validity on 1 April was obtained. If the first day of validity of this vignette is changed on 25 March, please note that the new start of validity must not be postponed to 24 March or earlier (i.e. into the past).
- Basically, the beginning of validity can be changed to the day on which the change is made, whereby the permission to use the road network subject to tolls only begins at the time of change.
Example: If today at 14:07 the start of validity of a digital vignette is changed to today, the road network subject to tolls can be used only from 14:07. The use of the road network subject to tolls before that time, referring to that vignette, is prohibited and constitutes toll evasion.
- The first validity day can only be changed between 1 December of the current year and 30 November of the following year (for details see items 1.5.2, 1.5.3 and 1.5.4).

Example:

Possible: Postponement from 1 April to 1 October of the same calendar year.

Not possible: Postponement from 1 October to 10 December of the same year or from 1 October to 1 February of the following calendar year. It is also not possible to postpone from 10 December to 15 November of the same calendar year.

If the digital vignette has already been purchased, the following changes cannot be made:

- Change of the period of validity. This means that
 - a one-day vignette cannot be changed to a ten-day, two-month or annual vignette;
 - a ten-day vignette cannot be changed to a one-day, two-month or annual vignette;
 - a two-month vignette cannot be changed to a one-day, ten-day or annual vignette;
 - an annual vignette cannot be changed to a one-day, ten-day or two-month vignette.
- Change of a digital vignette for a single-track vehicle to one for a multi-track vehicle and vice versa.
- Change from a digital vignette to a toll sticker

Changes defined as permissible above can be made under as follows:

- In the ASFINAG toll shop (after the registration and login) in the personal user account (see item 3.2.5)
- At the ASFINAG Service Center, ASFINAG toll stations and the point of sale where the digital vignette was purchased. The prerequisite is the presentation of the order confirmation or product ID, a copy of the registration certificate of the motor vehicle whose license plate number is currently registered, and – if the motor vehicle license plate number is changed – the registration certificate of the motor vehicle whose license plate number is to be registered.

In case of doubt, ASFINAG or the point of sale shall be entitled to demand further evidence.

3.6 RE-REGISTRATION FROM THE BEGINNING OF VALIDITY

After the beginning of validity only digital annual vignettes can be re-registered.

3.6.1 Re-registration without giving reasons

The registration holder is entitled to apply once during the period of validity of the digital annual vignette (see item 1.5) to have the digital annual vignette re-registered to another licence plate assigned to them without giving reasons.

An amount of EUR 18.00 including VAT must be paid as reimbursement of expenditures as a prerequisite for re-registration. Regarding the possible means and methods of payment see Appendix 2. For a successful re-registration in the ASFINAG toll shop, the following verification documents must be uploaded or presented at the ASFINAG toll stations, at selected points of sale offering this service:

- Copy of the registration certificate of the vehicle whose licence plate is currently registered and
- Copy of the registration certificate of the vehicle whose licence plate is to be registered

By re-registering a digital annual vignette without giving reasons, the licence plate holder confirms that the one-off option of re-registration without giving reasons has been used. Subsequent submission of any documents that serve as proof of authorisation for re-registration in certain cases (see item 3.6.2) is not possible.

Another (or even repeated) re-registration during the period of validity of the digital annual vignette is only possible in the cases mentioned in item 3.6.2.

The re-registration must be completed before the next use of motorways and expressways with the other vehicle licence plate number assigned to them. After the re-registration of the digital annual vignette, the authorization to use the motorways and expressways with the old motor vehicle license plate number expires.

Re-registration is possible in the ASFINAG toll shop (after registration and login) in the personal user account and at ASFINAG toll stations, as well as at selected points of sale that offer this service.

If the re-registration of a digital annual vignette is requested in the ASFINAG toll shop, this is a conditional re-registration (see item 3.6.3).

3.6.2 Re-registration in certain cases

In addition to the possibility of re-registration mentioned in item 3.6.1, a re-registration of the motor vehicle's license plate number registered in the toll system to a newly assigned motor vehicle license plate number of the same holder of the registration certificate can only be requested in the following cases:

- The holder of the registration certificate changes their place of residence and receives, due to the therefore necessary new motor vehicle registration, a newly assigned license plate number (this is the case, for example, when somebody changes their place of residence to another administrative district).
- The holder of the registration certificate receives a newly assigned motor license plate number due to the theft of their motor vehicle.
- The holder of the registration certificate is assigned a new license plate following the theft/loss of the motor license plate of their motor vehicle.
- The registration holder will be assigned a new registration number to the newly registered motor vehicle due to damage to their motor vehicle as a result of an accident or force majeure which makes it impossible to participate in road traffic with this motor vehicle (total loss).
- The registration holder receives a personalized license plate number.
- After waiving the personalized license plate number or after the personalized license plate has expired, a new license plate number is assigned to the holder of the registration for their vehicle.
- After the delivery of a license plate that is no longer permanently legible, the registration holder is assigned a new vehicle license plate number in accordance with § 50 Para. 2 KFG.
- The registration holder is assigned a new vehicle licence plate as a result of the issue of a licence plate pursuant to Section 49 para. 4 no. 5 KFG for vehicles with pure electric drive or with hydrogen fuel cell drive.
- In “similar cases” to the above mentioned in accordance with section 11(5) BStMG (Federal Road Toll Acts).

The next usage of the road toll network is only permitted if the re-registration has been completed in the toll system. After the re-registration of the digital annual vignette, the authorization to use the motorways and expressways with the old motor vehicle license plate number expires.

For a successful change, documents of proof need to be provided.

A re-registration is possible in the ASFINAG toll shop (after registration and login) in the personal user account and – subject to the following provisions – also at ASFINAG toll stations, from the ASFINAG Service Center and at selected points of sale offering this service.

In the event of a re-registration in the ASFINAG toll shop, the following verification documents must be uploaded or presented at the ASFINAG toll stations, at selected points of sale offering this service or from the ASFINAG Service Center:

- evidence which proves that the requirements for a re-registration after the start of validity of a digital annual vignette are met (e.g. proof of residence, proof of write-off (see item 2.3), theft report, notice of loss)
- copy of the registration certificate of the particular vehicle's license plate number that has been registered in the toll system, as well as the copy of the new vehicle's registration certificate for the license plate that should be registered instead
- provision of the order confirmation respectively the product ID (in case the re-registration is requested from the ASFINAG Service Center)

In cases of doubt, ASFINAG or those points of sale offering this service are entitled to request further evidence.

3.6.3 Conditional re-registration in the ASFINAG toll shop

If any re-registrations of the digital annual vignette is requested in the ASFINAG toll shop, the following steps are required:

- make an application for a conditional change
- upload appropriate documents of proof as *.pdf, *.jpg or *.tif
- Payment of an amount of EUR 18.00 including VAT (under the conditions listed below, this amount will be refunded). Regarding the possible means and methods of payment see Appendix 2.

The requested re-registration in the ASFINAG toll shop is (provisionally) immediately effective and permits the driver for the time of ten calendar days (whereby the day on which the request has been made is not counted) to use the road network subject to tolls. Therefore, for this certain time period the digital vignette belonging to the previous motor vehicle license plate number expires.

During these ten calendar days ASFINAG will verify the uploaded documents of proof. In certain cases (e.g. change of residence within Austria), the verifying process can be automatically supported.

ASFINAG will try to inform the applicant about the proof status by the applicant's given e-mail address. Apart from that, there is the possibility to query the vignette registry at any time whether there is a valid digital vignette for the respective motor vehicle license plate number.

After a positive verification of evidence the digital vignette will be permanently re-registered to the newly assigned motor vehicle license plate number.

In addition, the amount of EUR 18.00 including VAT will be refunded in the following cases:

- a newly assigned motor vehicle license plate number due to theft of vehicle
- a newly assigned motor vehicle license plate number due to theft/loss of the (originally registered) motor vehicle license plate number
- a newly assigned motor vehicle license plate number due to write-off

- a newly assigned motor vehicle license plate number due to the return of a license plate which is no longer easily legible in accordance with section 50 (2) KFG.
- Newly assigned licence plate number as a result of the issue of a licence plate in accordance with § 49 para. 4 Z 5 KFG

In the case of a change due to a newly assigned motor vehicle license plate number as a result of change of residence, assignment or expiration of the personalised plates, waiver of the personalised plates, as well as in similar cases and in the event of re-registration without giving reasons, the amount of EUR 18.00 incl. VAT will be considered as a reimbursement of expenditures and therefore not be refunded.

If the verification of evidence is negative, the (provisional) re-registration expires at the end of the tenth calendar day and the digital vignette is again valid for the originally registered motor vehicle license plate number. The paid amount of EUR 18.00 incl. VAT will be considered as a reimbursement of expenditures and therefore not be refunded.

3.6.4 Re-registration via the ASFINAG Service Center

Re-registrations in regard to the digital annual vignette can only be requested from the ASFINAG Service Center (see item 1.13) in the following cases:

- a newly assigned motor vehicle license plate number due to theft of vehicle
- a newly assigned motor vehicle license plate number due to theft/loss of the (originally registered) motor vehicle license plate number
- a newly assigned motor vehicle license plate number due to write-off

In this regard suitable verification documents have to be submitted in order to grant the re-registration, whereby verification documents are accepted in the following form: *.pdf, *.jpg or *.tif.

The requested re-registration only come into effect after the ASFINAG Service Center has finished the verification of evidence with a positive result.

In case of a newly assigned license plate number due to change of residence, allocation or expiry of the personalised plates, waiver of the personalised plates, or in similar cases and in the event of re-registration without giving reasons,, the re-registration can only be made in the ASFINAG toll shop (see item 3.6.1) after paying the reimbursement of expense.

ASFINAG will inform about the result of the verification process. Apart from that, there is the possibility to query the vignette registry at any time whether there is a valid digital vignette for the respective license plate number.

After a positive verification of evidence the digital vignette will be permanently re-registered to the newly assigned motor vehicle license plate number and permits the driver to use the road toll network. The digital vignette for the previous motor vehicle license plate number expires at this point.

3.6.5 Re-registration at ASFINAG toll stations and selected points of sale

At ASFINAG toll stations and selected points of sale that offer this service, re-registration without giving reasons and re-registration can be requested in the following cases:

- a newly assigned motor vehicle license plate number due to change of residence
- a newly assigned motor vehicle license plate number due to theft of vehicle
- a newly assigned motor vehicle license plate number due to theft/loss of the (originally registered) motor vehicle license plate number
- a newly assigned motor vehicle license plate number due to write-off
- Newly assigned personalised plates
- Newly assigned licence plate number after renouncing the personalised plates or after the personalised plates have expired
- a newly assigned motor vehicle license plate number due to the return of a license plate which is no longer easily legible in accordance with section 50 (2) KFG.
- Newly assigned licence plate number as a result of the issue of a licence plate in accordance with § 49 para. 4 Z 5 KFG

Suitable documents of proof must be submitted for the change of the license plate number.

As a condition for the change an amount of EUR 18.00 must be paid in the event of a change of residence, the assignment or the expiration or waiver of the personalised plates – as a precondition for re-registration.

The requested re-registration becomes effective after a positive verification of evidence and from this point on entitles the holder to use the road network subject to tolls with the new motor vehicle license plate number. The digital vignette for the previous motor vehicle license plate number expires at this point.

The ASFINAG toll station or point of sale will issue a confirmation of the re-registration of the motor vehicle license plate number. The customer must check the confirmation to ensure that the data entered there (in particular the registered motor vehicle license plate number and the validity period of the digital vignette) are entered correctly. Any need for correction must be reported immediately to the toll collector or point of sale.

3.6.6 Re-registration of the digital vignette and the digital section toll

If both a digital annual vignette and one or more multi-trip cards (Part AII, item 3.2.3) or the digital section toll FLEX service (Part AII, item 4.2.2) are registered on a vehicle licence plate, the above mentioned provisions apply mutatis mutandis. If the re-registration of several products registered to the same licence plate number (digital annual vignette, multi-trip card, digital section toll FLEX service) is applied for in one application, a possible reimbursement of expenditures of EUR 18.00 is only payable once.

For annual cards (Part AII, item 3.2.2) purchased before 1 December 2023, the provisions set out in this item for multi-trip cards apply accordingly.

PART A II: TOLLING REGULATIONS FOR SINGLE-TRACK MOTOR VEHICLES AND MULTI-TRACK MOTOR VEHICLES WITH A MAXIMUM TECHNICALLY PERMISSIBLE LADEN MASS OF NO MORE THAN 3.5 T FOR THE EXISTING SECTION TOLLS ON THE AUSTRIAN MOTORWAY AND EXPRESSWAY NETWORK: A 9, A 10, A 11, A 13, S 16

1 GENERAL REGULATIONS

1.1 DEFINITION OF TERMS

- **Valid digital section toll entitlement:** This means that the vehicle license plate number is duly registered in ASFINAG's toll system for the time period of use of the section subject to toll payment and the section toll authorization is already valid.
- **Order confirmation:** This is a document issued when a digital section toll has been obtained (registration in the toll system). This document particularly shows data of the license plate number registered in the toll system, vehicle type, validity period as well as the product-ID, which serves to clearly identify the digital vignette.
- **Vignette registry:** This is a public register that anyone can use free of charge to check the period for which a digital vignette or digital section toll is registered by entering a vehicle licence plate number. The vignette registry can be found at <https://evidenz.asfinag.at/>.
- **Vehicle type:** Differentiation between single-track vehicles and multi-track vehicles with a maximum technically permissible laden mass of up to 3.5 t.
- **Digital subscription:** A digital subscription is an unlimited procurement of digital annual vignettes or multi-trip cards similar to a subscription contract.

1.2 SCOPE OF APPLICATION

The Tolling Regulations Part A II apply to single-track motor vehicles and multi-track motor vehicles with a maximum technically permissible laden mass of no more than 3.5 t.

Unless otherwise indicated, references always refer to this Part A II of the Tolling Regulations.

According to § 10 para. 3 last sentence of the BStMG [Federal Road Tolls Act], motor vehicles with three wheels are considered as single-track motor vehicles.

For multi-track motor vehicles that have never been registered for traffic and carry test drive or transfer license plates, the rates according to item 3 apply, provided their tare weight does not exceed 3.5 t. In the case of journeys with test drive or transfer licence plates, a copy of the type certificate or a confirmation of the producer or their authorised representative in accordance with § 29 para. 2 KFG about the tare weight of the motor vehicle must be carried along, which must be presented when requested by toll enforcement officers or the toll personnel.

No section toll must be paid for trailers being towed by multi-track vehicles with a maximum technically permissible laden mass of up to 3.5 t as well as sidecars and single-track motor vehicles.

Pursuant to § 33 para. 18 line 8 BStMG, motor vehicles with a maximum permissible weight of no more than 3.5 t at the time of use of the toll road network, that were first registered for traffic before 1 December 2023, and for which the maximum permissible weight (MPW) was set at no more than 3.5 t before 1 December 2023, are deemed to be vehicles with a maximum technically

permissible laden mass of no more than 3.5 t until 31 January 2029 and are therefore subject to the section toll provisions.

If the transitional regulation of § 33 para. 18 line 8 BStMG (see item 1.2.) is utilised, the driver must provide proof of fulfilment of the requirements and send it to tzgm@asfinag.at.

1.3 JURISDICTION AND APPLICABLE LAW

The exclusive place of jurisdiction for all claims against ASFINAG under civil law arising out of these Tolling Regulations and/or the use of the road network subject to tolls shall be the court that has jurisdiction as regards such matters for the third district in Vienna. Only Austrian law applies, excluding the conflict of laws rules of private international law.

1.4 RESPONSIBILITY AND CUSTOMER SERVICE (ASFINAG SERVICE CENTER)

All queries or applications for refunds should be addressed to the ASFINAG Service Center of ASFINAG Maut Service GmbH:

ASFINAG Maut Service GmbH
Alpenstraße 99
5020 Salzburg, Austria
Austria

Telephone number: 0800 400 12 400 (free of charge from Austria and Germany)
Telephone number: +43 1 955 1266
Fax number: +43 1 955 1277
E-mail /website: info@asfinag.at / <https://www.asfinag.at>

2 PAYMENT OF THE SECTION TOLL

2.1 ROUTES SUBJECT TO TOLLS

2.1.1 Designation of the section toll segments and toll stations

The table below lists the names of the toll sections or section toll segments, and toll stations that are the subject matter of and are subject to Tolling Regulations Part A II:

Motorway	Designation of the toll section / of the section toll segment	Name of the toll station
A 9 Pyhrn motorway between the Spital am Pyhrn and Ardnig junctions (Bosruck tunnel) and between the St. Michael and Übelbach intersection (Gleinalm tunnel)	Bosruck/Gleinalm	toll station Bosruck
		toll station Gleinalm
A 10 Tauern motorway between the Flachau and Rennweg am Katschberg (Tauern and Katschberg tunnels) junctions	Tauern/Katschberg	St. Michael im Lungau toll station
A 11 Karawanken motorway between the St. Jakob im Rosental junction and the Slovenian state border (Karawanken tunnel)	Karawanken	toll station Rosenbach
A 13 Brenner motorway	Brenner	Schönberg toll station
S 16 Arlberg expressway between the St. Anton am Arlberg and Langen am Arlberg junctions.	Arlberg	toll station St. Jakob

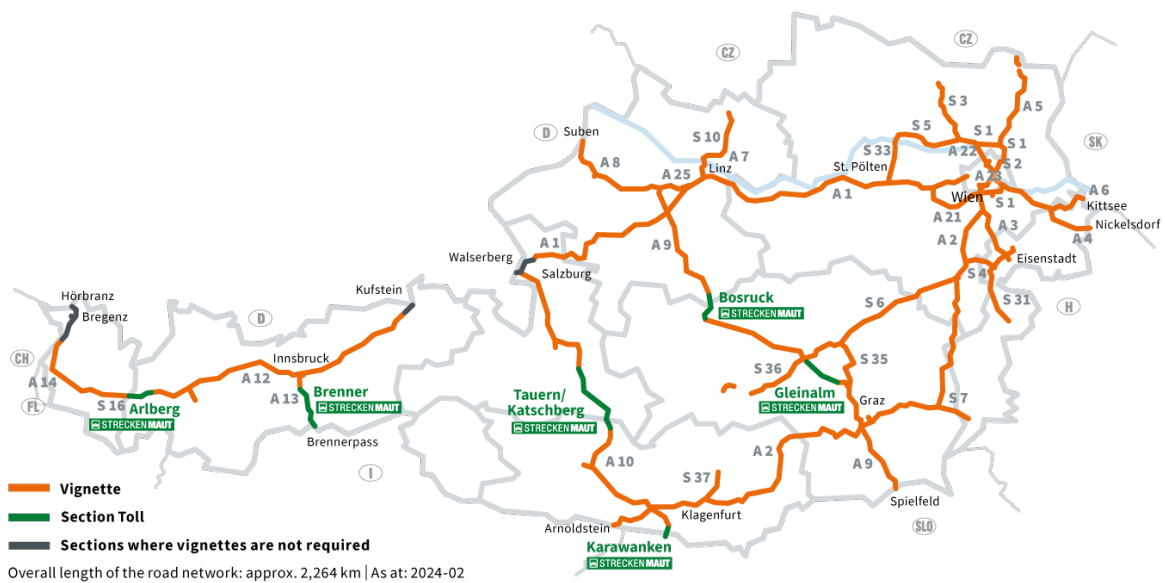

Figure 9

2.1.2 Signage

Drivers are notified of the toll obligation by appropriate signage at the start of each toll section (see for instance Figure 9a)



Figure 9a

2.2 LANE GUIDANCE

Vehicles may only drive through existing toll stations on the specially marked lanes. These lanes can be operated either in so-called closed or in so-called open toll lane operation.

2.2.1 Closed toll lane operation A 9, A 10, A 11, A 13, S 16

At all toll stations, toll lanes are operated in closed toll lane operation (toll lane operation with barriers).

The barrier located in the closed toll lane opens for motor vehicles with a maximum technically permissible laden mass of no more than 3.5 t, whose vehicle license plates are duly registered in the toll system for the respective section toll segment (i.e. which have a valid digital section toll

authorisation or digital section toll FLEX). If this is not the case, the barrier remains down. In this case, the toll must be paid on site at the toll station.

Toll lanes in which it is possible to pay the toll on site at the toll station are specially marked (without special floor markings, but with information signs in white or with the words "Buy Ticket") (see example in Figure 9b).

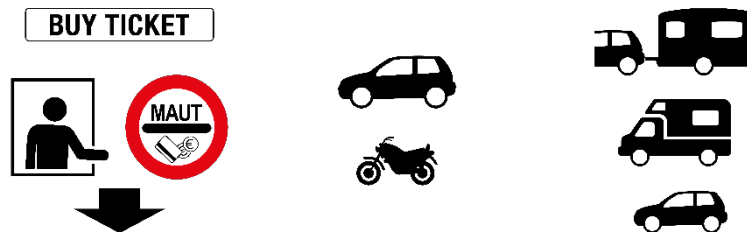

Figure 9b

Toll lanes that are open to motor vehicles with a maximum technically permissible laden mass of no more than 3.5 t, whose license plates have a valid digital section toll authorisation for the respective section toll segment (see items 1.1, 1.3.1) or are registered for the digital section toll FLEX (see item 4.2.2), are specially marked (with signs in green or with the notice "Prepaid Only") (Figure 9c).



Figure 9c

2.2.1.1 Mixed toll lane operation at the A 10 and A 13 secondary toll stations

At the secondary toll stations on the A 10 Zederhaus and St. Michael/Lungau and on the A 13 Zenzenhof, Igls Patsch, Schönberg Stubaital, Matrei Steinach, Nösslach and Brennersee, the so-called closed toll lanes are operated in mixed mode.

The toll lane may therefore be used by both vehicles with a maximum technically permissible laden mass of no more than 3.5 t and vehicles with a maximum technically permissible laden mass of more than 3.5 t (see Tolling Regulations Part B).

There is no separate marking with regard to toll lane operation.

2.2.2 Open toll lane operation

In contrast to the so-called closed toll lanes (lane operation with barriers), lanes at the toll stations can also be in open operation, i.e. without barriers.

2.2.2.1 Open toll lane operation on A 10, A 11 and S 16

At the toll stations on the A 10, A 11 and S 16, one lane will be opened in open toll lane operation only for motor vehicles that are subject to the distance-based toll. These lanes will be clearly marked as such (see Figure 9d).

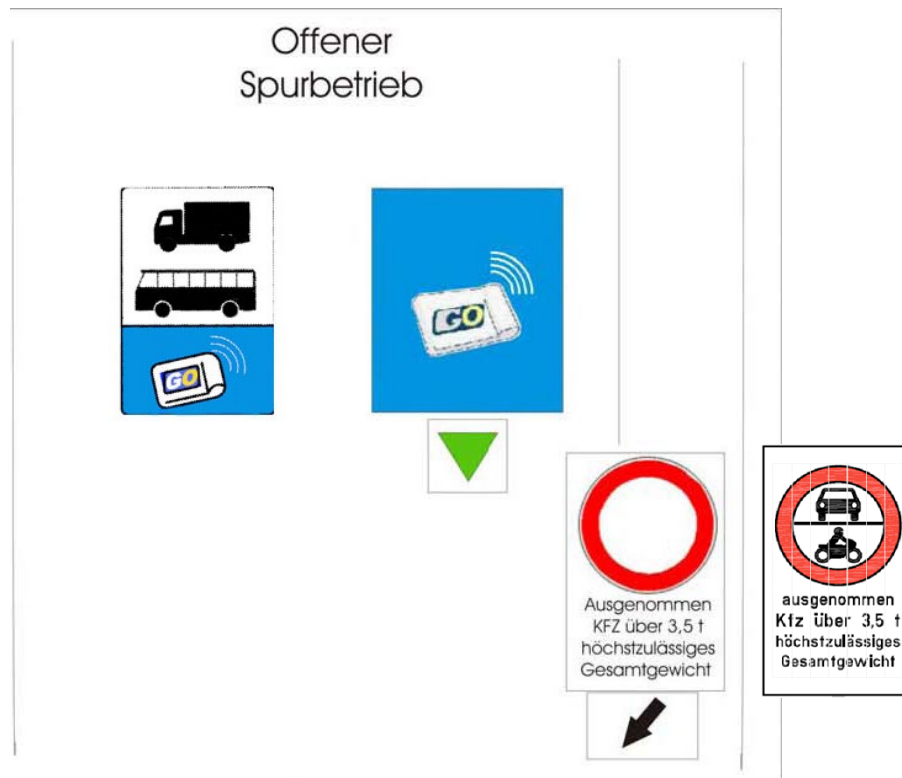

Figure 9d

In open toll lane operation, motor vehicles with a maximum technically permissible laden mass of no more than 3.5 t (category 1) are prohibited from driving in this toll lane in accordance with the StVO. The use of this lane by these motor vehicles is prohibited and constitutes an administrative offence, whereby a distinction must be made between administrative offences according to StVO and administrative offences according to BStMG (Federal Road Toll Acts) (see item 7.1). It should be noted that motor vehicles with a maximum technically permissible laden mass of more than 3.5 t, which are covered by the transitional rule pursuant to Section 33 para. 18 Z 8 BStMG (Federal Road Toll Acts), are deemed to be motor vehicles with a maximum technically permissible laden mass of no more than 3.5 t until 31 January 2029.

2.2.2.2 Open toll lane operation on A 9

In open lane operation at the toll stations on the A 9 (Bosruck, Gleinalm), two lanes each are open for motor vehicles with a maximum technically permissible laden mass of no more than 3.5 t whose licence plates have a valid digital section toll authorisation for the Bosruck/Gleinalm section toll segment (see items 1.1., 2.1.2) or are registered for the digital section toll FLEX (see item 4.2.2). These lanes are specially marked (by green road markings and green signs or with the words "Prepaid Only") (see Figure 9c).

These lanes can also be used in mixed toll lane operation (i.e. both by vehicles with a maximum technically permissible laden mass of over 3.5 t (see Tolling Regulations Part B and C) and by vehicles with a maximum technically permissible laden mass of no more than 3.5 t) (see Figure 9e).



Figure 9e

Motor vehicles with a maximum technically permissible laden mass of no more than 3.5 t, whose vehicle license plate numbers are not properly registered in the toll system for the Bosruck/Gleinalm section toll segment (i.e. which do not have a valid digital section toll authorisation or digital section toll FLEX), must be allocated to those lanes which allow tolls to be paid locally at the toll station. These lanes are specially marked (without special road marking, but with signs in white or with the indication "Buy Ticket") (see Figure 9b).

Use of the open lanes without having properly paid the toll constitutes an administrative offence (see item 7.1).

2.2.2.3 Open toll lane operation at the Schönberg A 13 toll station

Open toll lane operation at the Schönberg toll station on the A 13 is mixed.

The toll lane is open to motor vehicles with a maximum technically permissible laden mass of no more than 3.5 t (see Tolling Regulations Part B and C) as well as to motor vehicles with a maximum technically permissible laden mass of up to 3.5 t whose licence plates have a valid digital section toll authorisation for the Brenner digital section toll segment (see items 1.1, 2.1.1, 3.1.4) or are registered for the digital section toll FLEX (see item 4.2.2). This lane is clearly marked as such (see Figure 9e).

Motor vehicles with a maximum technically permissible laden mass of no more than 3.5 t, whose vehicle license plate numbers are not properly registered in the toll system for the Brenner overall section toll segment (i.e. which do not have a valid digital section toll authorisation or digital section toll FLEX) must be allocated to those lanes which allow tolls to be paid locally at the toll station. These lanes are specially marked (with signs in white or with the indication "Buy Ticket") (see Figure 9b).

Use of this toll lane without having properly paid the toll constitutes an administrative offence (see item 7.1).

2.2.3 Special obligations to cooperate A 9 and A 13

If the driver of a motor vehicle subject to tolls intends to use an open toll lane of the Bosruck or Gleinalm toll stations on the A 9 or the Schönberg toll station on the A 13, they must ensure that their vehicle licence plate is properly registered in the toll system for the relevant section toll segment (i.e. has a valid digital section toll authorisation or digital section toll FLEX). This is done by querying the vehicle registration number in the vignette registry (see item 1) immediately before using the toll road (section toll segment), which provides information as to whether a motor vehicle has a valid digital section toll authorisation, for which section toll segment and for which period of time it is valid.

Furthermore, every vehicle driver has to – according to section 102(2) KFG – make sure that the official license plate number of the vehicle that is liable for toll, is completely and permanently visible during the journey and has not been covered by dirt or snow, respectively damaged deformed in such a way that it is illegible.

2.3 EXEMPTIONS FROM THE TOLL OBLIGATION

2.3.1 Permanent exemptions

The following motor vehicles are permanently exempt from the mandatory section toll:

- Motor vehicles on which headlights or warning lights with blue light are visibly attached according to § 20 para. 1 no. 4 KFG, as well as motor vehicles of the public security service, the tax administration, the judicial guard, foreign security authorities according to § 2 para. 3 of the Police Cooperation Act, foreign customs and judicial authorities on which headlights or warning lights with blue light are visibly attached according to § 20 para. 5 KFG. The exemption from the section toll obligation must be applied for with ASFINAG annually by 30 September of each year for the following year and it shall be demonstrated by appropriate evidence that the conditions set forth in this provision are met and for which motor vehicles the exemption is applied for.
- If motor vehicles of fire brigades and fire brigade associations, on which headlights or warning lights with blue light are visibly attached in accordance with § 20 para. 1 no. 4 KFG and para. 5 KFG, have special-area licence plates for fire brigades in accordance with § 26 para. 4 lit. i Motor Vehicle Act Implementation Ordinance 1967, the exemption from the section toll obligation must be applied for once from ASFINAG.

If these motor vehicles are not fitted with special-use licence plates, the exemption from the section toll obligation must be requested from ASFINAG annually by 30 September of each year for the following year and it shall be demonstrated by appropriate evidence that the conditions set forth in this provision are met and for which motor vehicles the exemption is applied for.

- Motor vehicles on which headlights or warning lights with blue lights are visibly attached in accordance with § 20 Para. 5 KFG and which are registered to non-profit organisations whose tasks are carried out by members or employees who work predominantly on a voluntary basis. The regular use of motor vehicles for the purposes of these devices (or a device specified in § 20 Para. 1 No. 4 KFG) is deemed equivalent to a registration if headlights or warning lights with blue light are visibly attached to the motor vehicles in accordance with § 20 Para. 5 KFG. The respective institution shall apply for the exemption from the section toll

obligation to ASFINAG in writing by 30 September of each year for the following year and shall provide appropriate evidence that the conditions laid down in this provision are fulfilled and for which motor vehicles the exemption is applied for.

- Motor vehicles with flashing blue light in accordance with section 2(1)(25) StVO 1960, (operational vehicles) for the time one of these signals is used, whereby ASFINAG is authorised to randomly check the correctness of the declaration that the vehicle has been operationally used by contacting the appropriate command and control centre afterwards. The exemption of the section toll obligation is also valid for the return journey in case the signals have been used.
- Army vehicles (§ 2 para. 1 no. 38 KFG 1967)
- Vehicles that are used within the scope of the agreement among the states party to the North Atlantic Treaty and the other states participating in the Partnership for Peace regarding the status of their forces ('PfP-SOFA'). If non-military motor vehicles are used for these trips, they shall provisionally be subject to the section toll obligation. The toll paid for these journeys will be reimbursed by ASFINAG free of charge. The application for reimbursement must be submitted directly to ASFINAG Toll Service GmbH (see Appendix 6b) by the competent state authority after completion of the journeys, together with the relevant evidence.
- Motor vehicles used in the performance of peace-keeping operations within the framework of an international organisation, the Organisation for Security and Cooperation in Europe or the European Union pursuant to a decision taken under the common foreign and security policy.
- Confiscated vehicles that use the road network subject to section tolls and to which an official tax authority registration number has been attached are not liable for the section toll. The tax authority has to request an exemption from the section toll obligation from ASFINAG in advance and in written form.

Vehicles that have blue headlights or warning lights visibly attached to the exterior, but are not registered and therefore carry transfer license plates or other equivalent plates and that use the road network subject to section tolls are not exempt from the section toll obligation.

2.3.2 Temporary exemptions

2.3.2.1 Exceptions for humanitarian aid transports

In addition to the above provision, ASFINAG may in accordance with section 5(2) BStMG (Federal Road Toll Acts) and depending on the circumstances, exempt vehicles with a maximum technically permissible laden mass of no more than 3.5 t that are delivering humanitarian aid in the event of emergencies or disasters from the toll obligation.

An exemption from the section toll obligation for journeys within the context of humanitarian aid transports applies without exception only in the event that there is an occasion within the meaning of Section 5 para. 2 BStMG (Federal Road Toll Acts) and the specific occasion is announced in the Tolling Regulations at this point.

In order to be able to make such a journey without paying the toll charge at a toll station (section toll), the exemption request (Appendix 3c) must be completed and duly signed and sent by e-mail

(ausnahmeantrag@asfinag.at) or by fax (+43 1 955 1277) at least 24 hours before using the road network subject to section tolls (application available at <https://www.asfinag.at/mautordnung>). The applicant will receive a written order confirmation.

The completed and signed application must be handed in at the relevant toll station. If a return journey is to be made, a copy of the original application form must be made and handed over at the toll station on the return journey.

Currently applicable cases:

The emergency situation due to the armed conflict in Ukraine is considered a case of necessity within the meaning of Section 5 (2) BStMG (Federal Road Toll Acts). The term "humanitarian aid transports" includes journeys for the purpose of transporting goods and merchandise as well as journeys for the purpose of transporting persons who are considered displaced persons within the meaning of the Displaced Persons Ordinance, Federal Law Gazette II No. 92/2022. The toll exemption is unlimited in time and applies from 01.03.2022.

For humanitarian reasons due to the armed conflict in Ukraine, all motor vehicles with Ukrainian licence plates are exempt from the section toll. This toll exemption is provisionally limited until 30 September 2024 and applies from the publication of the Tolling Regulations on the internet at <https://www.asfinag.at/mautordnung>.

2.3.2.2 Exemptions at the request of the Federal Ministry of the Interior in the context of state crisis and disaster control management or international disaster aid

At the request of the Federal Ministry of the Interior, trips carried out by motor vehicles with a maximum technically permissible laden mass of no more than 3.5 t within the framework of state crisis and disaster protection management or international disaster relief may be exempted from the payment of tolls on a case-by-case basis.

To enable such trips to be made without the obligation to pay the toll (section toll), the Federal Ministry of the Interior must notify ASFINAG of these trips, listing the license plate number of the motor vehicles concerned and announcing the expected route and the exemption period before using the road network subject to section tolls.

The written confirmation of the Federal Ministry of the Interior (BMI) concerning the concrete exception to the section toll obligation during the toll-free trip must be carried in the affected motor vehicles and presented on request as evidence of the exemption authorisation.

3 TOLL RATES

Each toll rate includes 20% VAT and is explained in the tables below.

Amendments to the toll rates during the period of validity of the various pre-paid toll cards do not have any bearing on the toll rate already paid. Such amendments shall not, therefore, result in any claims from whatever party regarding retrospective payment or refund of the toll difference.

3.1 STANDARD TOLL RATES

The following toll rates apply to the section toll segments:

3.1.1 A 9 Gleinalm and A 9 Bosruck

	Card type	Price	Gleinalm	Bosruck
A 9 Gleinalm Bosruck	Single trip		EUR 10.50	EUR 6.50
	Multi-trip card ⁽¹⁾	EUR 71.50		
	Multi-trip card for commuters ⁽²⁾		EUR 10.50	EUR 6.50

(1) see item 3.2.3

(2) see item 2.3.4

3.1.2 A 10 Tauern/Katschberg

	Card type	Price	Total toll section	Toll road subsection
A 10 Tauern/ Katschberg	Single trip		EUR 13.50	EUR 7.00
	Multi-trip card ⁽¹⁾	EUR 81.00		
	Multi-trip card for commuters ⁽²⁾	EUR 13.50		

(1) see item 3.2.3

(2) see item 2.3.4

Entire route: Every journey via the St. Michael im Lungau toll station
Toll road subsections: St. Michael im Lungau – Rennweg and vice versa or
St. Michael im Lungau – Flachau and vice versa or
Zederhaus – Flachau and vice versa

3.1.3 A 11 Karawanken

	Card type	Price
A 11 Karawanken	Single trip	EUR 8.20
	14-trip monthly card ⁽¹⁾	EUR 36.70

(1) see item 3.2.9

3.1.4 A 13 Brenner

	Card type	Price	Total toll section	Toll road subsection 1	Subsection 2	Subsection 3	Subsection 4
A 13 Brenner	Single trip		EUR 11.00	EUR 1.00	EUR 3.00	EUR 3.50	EUR 5.50
	Multi-trip card ⁽¹⁾	EUR 66.00					
	Multi-trip card for commuters ⁽²⁾	EUR 11.00					

(1) see item 3.2.3

(2) see item 3.2.4

Entire section: every journey via the Schönberg toll station
 Toll road subsection 1 Innsbruck – Zenzenhof or Brenner Pass – Lake Brenner and vice versa
 Toll road subsection 2: Innsbruck – Patsch/Europa Bridge or Brenner Pass – Nösslach and vice versa
 Toll road subsection 3 Innsbruck – Stubaital and vice versa
 Toll road subsection 4 Matrei – Brenner Pass and vice versa

3.1.5 S 16 Arlberg road tunnel

	Card type	Price
S 16 Arlberg Tunnel	Single trip	EUR 11.50
	Multi-trip card ⁽¹⁾	EUR 69.00
	Multi-trip card for commuters ⁽²⁾	EUR 11.50

(1) see item 3.2.3

(2) see item 3.2.4

3.2 TYPE OF RATES

The options to pay the toll are explained in item 4.

3.2.1 Single trip

A single trip ticket is valid for one year from the date of issue and permits to use a particular section toll segment for one driving direction.

3.2.2 Annual card

Annual cards were only offered up to and including 30.11.2023. An annual card is a card linked to the vehicle licence plate number with one-year validity and entitles the holder to unlimited use of a specific section toll segment.

3.2.3 Multi-trip card

A multi-trip card is a card linked to the vehicle licence plate number, which entitles the holder to an unlimited number of journeys on a specific section toll segment within 365 days, whereby the first day of validity can be selected at the time of purchase. The last possible first validity day of a multi-trip card from the current calendar year is 31 December from 2024. For possible restrictions on the choice of the first validity day, see in particular item 4.2.1. No multi-trip cards are offered for the A 11 Karawanken motorway.

3.2.4 Multi-trip card for commuters

The multi-trip card for commuters entitles the holder to an unlimited number of journeys on a specific section toll segment within 365 days, but in the case of a fixed-term employment relationship subject to income tax only until the end of the employment relationship. For all

sections, with the exception of the A 11 Karawanken motorway, multi-trip cards for commuters can be obtained if the following conditions are fulfilled (Appendix 3e):

- The applicant is an employee (also applies to military personnel, Appendix 3f).
- Verifiable and plausible confirmation of the place of residence and place of work are provided. Use of the toll road must either be unavoidable or at least constitute the shortest distance.
- The passenger car or single-track motor vehicle is registered to the commuter.

For each subsection of the section toll segments A 9 Bosruck/Gleinalm the aforementioned requirements will be checked separately.

3.2.5 Multi-trip card for people with disabilities

People with disabilities are entitled to the provision of a free multi-trip card for a multi-track motor vehicle registered in their name with a maximum technically permissible laden mass of no more than 3.5 tonnes, subject to the following conditions.

For people with disabilities who already have a free digital vignette in accordance with Part A I, item 1.6.1, a free multi-trip card with the same validity period as the free digital vignette is automatically booked for the same motor vehicle license plate number.

If no free digital vignette has been registered, a free multi-trip card, which entitles the holder to an unlimited number of journeys within 365 days of issue, is available under the following conditions:

- Presentation of a disabled person's parking permit (according to section 29b StVO)
- Motor vehicle that has been approved for a disabled-accessible operation (disabled vehicle) or at least a restriction to driving vehicles without a clutch pedal (automatic transmission) – entry of the restriction in the disabled person's driver's license.
- The multi-trip card for drivers of disabled vehicles is only issued for a motor vehicle registered in the name of the disabled driver.

An entitlement to a free multi-trip card exists only for a vehicle licence plate specified by the entitled person, even if several motor vehicles with different licence plates are registered to them.

The card is also issued in the name of the beneficiary and is, in derogation of the general regulations for multi-trip cards, valid for all ASFINAG section toll segments (Tolling Regulations Part A II), with the exception of A 11 Karawanken motorway.

3.2.6 Multi-trip card for disabled persons on the A 13

A multi-trip card for people with disabilities to use the A 13 entitles them to an unlimited number of journeys within 365 days of issue and can be purchased at a price of EUR 11.00 (including 20% VAT) if the following conditions are met.

This card can be obtained by:

- holders of official certificates and victim's identity cards whose reduction in earning capacity is at least 50%
- seriously disabled people according to section 9(2) of the War Victims Welfare Act
- blind civilians in possession of a blind person's identity card;

- disabled people who can provide evidence that they suffer from at least 50% disability.
- The multi-trip card for disabled drivers is only issued for a motor vehicle registered to the disabled driver.

This multi-trip card is valid for the A 13 Brenner motorway only.

3.2.7 Monthly card for the A 13

Monthly cards were only offered up to and including 30/11/2023. This monthly card is restricted to one particular vehicle registration number and entitles the driver to an unlimited number of trips on the A 13 Brenner motorway within 30 calendar days from the date of issue. The card, which can be obtained for EUR 45.00 (incl. 20% VAT), is issued upon presentation of the vehicle registration certificate. The A 13 monthly card is available until 30 November 2023.

3.2.8 Multi-trip resident's card for the A 13

Inhabitants of the municipalities of Ellbögen, Gries am Brenner, Gschnitz, Matrei am Brenner, Mühlbachl, Navis, Obernberg am Brenner, Patsch, Pfons, Schmirn, Steinach am Brenner, Trins, Vals in the Wipp Valley (Wipptal), Schönberg, Mieders, Fulpmes, Telfes, and Neustift in the Stubai Valley (Stubaital) will receive the multi-trip resident's card for as long as they meet the conditions listed directly below:

- The registration holder is a natural person.
- A valid confirmation of the applicant's main place of residence is provided.
- The passenger car or single-track motor vehicle is registered to the applicant.
- The passenger car or single-track motor vehicle is only registered to a private person and not as a company vehicle.

The A 13 multi-trip resident's card entitles the holder to an unlimited number of journeys within 365 days of issue and can be purchased at a price of EUR 11.00 (including 20% VAT) if the requirements are met (Appendix 3d).

3.2.9 14-trip monthly card for the A 11

This is a card linked to the vehicle via the vehicle registration number. It entitles the holder to 14 journeys through the Karawanken tunnel during 30 calendar days from the date of issue of the card. Unused trip credits cannot be refunded at the end of the 30 calendar days.

3.3 LOSS OF LICENSE PLATE NUMBER RELATED CARDS

In the event of loss of a license plate number related card, a new card can be issued for EUR 7.00 (incl. 20% VAT) at the toll station as reimbursement of expenditures.

4 PAYMENT METHODS

4.1 PAYMENT AT THE ASFINAG toll station

The toll must be paid in euros (EUR) at the ASFINAG toll stations. Information on which payment methods and means are permitted is contained in Appendix 2 (at

<https://www.asfinag.at/mautordnung>) and can be obtained from the ASFINAG Service Center (see item 1.5)

4.2 PURCHASE IN ADVANCE

4.2.1 Procurement via the ASFINAG toll shop and authorised online distribution partners: Payment in advance – Pre-Pay

Selected single-trip tickets (item 3.2.1), as well as multi-trip cards (item 3.2.3), are also offered in the ASFINAG toll shop and from authorised online distribution partners.

Further information on the authorised online distribution partners and the section toll authorisations available there can be found on the internet at

<https://www.asfinag.at/vertriebsstellen/>.

The purchase is possible in the ASFINAG toll shop and authorised online distribution partners from within Austria, the European Union as well as in the EEA states and Switzerland.

In regard to the start of validity and the required details, the regulations mentioned in Part A I, items 3.2.1.1 and 3.2.1.2 are in corresponding effect. Please refer to 4.3.2 and 4.4 regarding the service for obtaining the digital subscription for multi-trip cards (item 3.2.3) and the associated specific features.

4.2.2 Pre-registration in the ASFINAG toll shop and with authorised online distribution partners: payment afterwards – digital section toll FLEX

Single trips (item 3.2.1) are also offered in the ASFINAG toll shop and from authorised online distribution partners for retrospective payment (Digital Section Toll FLEX).

Further information on the authorised online distribution partners and the section toll authorisations available there can be found on the internet at

<https://www.asfinag.at/vertriebsstellen/>.

Registration for digital section toll FLEX can be made through the ASFINAG toll shop or authorised online distribution partners (item 4.3.3). This is possible via the ASFINAG toll shop and authorised online distribution partners from within Austria, the EU, as well as the EEA states and Switzerland.

As soon as the registration process has been successfully completed in the ASFINAG toll shop or with authorised online distribution partners, the motor vehicle license plate is registered for the purposes of the digital section toll FLEX. From this point onwards, the licence plate number will also be displayed in the vignette registry as registered for the digital section toll FLEX service. As long as the licence plate number appears in the vignette registry, the vehicle is authorised to use the road network subject to the section toll.

The section toll due for the respective toll section is deemed to have been properly paid within the meaning of § 32 para. 1 BStMG after 28 days of using the toll section, provided the vehicle licence plate number was registered for the digital section toll FLEX at the time of passing through the toll station and payment of the section toll rate due has been made in accordance with item 3.1. within 28 days of using the section toll segment. This applies both when using the entire section and when using a toll road subsection of a section toll segment, and in the case of the A9 motorway when using the Bosruck and Gleinalm sections.

If the vehicle licence plate number is registered for the digital section toll FLEX, the rate for a single trip (item 3.1.) valid at the time of the trip will be debited from the means of payment deposited at the time the toll section is used, both when using the entire section and when using a toll road subsection of a section toll segment and, in the case of the A9, when using the Bosruck and Gleinalm sections after passing through the toll station (starting the single trip).

For passages from 18.04.2024, the following applies:

Within 365 days of the first passage, a maximum of the rate of a multi-trip card (item 3.1.) valid at the time of the first passage must be paid for each section toll segment, irrespective of the number of trips made. For this purpose, the rate of the single trips made within 365 days of the first passage (on entire sections and toll road subsections or the Bosruck and Gleinalm sections of the A9) are totalled and the rate of the single trip is not charged or not charged in full for those trips within 365 days of the first passage that would lead to the rate of the single trip being exceeded. Single trips that are not paid for as part of the digital section toll FLEX service are not taken into account.

As no multi-trip card is offered for the A 11 Karawanken motorway, the applicable rate for a single trip must always be paid when using the digital section toll FLEX service, regardless of the number of trips made.

If collection is not possible from the payment method deposited at the time the toll section is used (for whatever reason), the digital section toll FLEX service will be disabled at the end of the same day. From this time the motor vehicle license plate no longer appears in the vignette registry. From this point in time, the vehicle licence plate is no longer considered registered for the purposes of the digital section toll FLEX for the duration of the block and the vehicle licence plate no longer appears in the vignette registry as registered for the digital section toll FLEX service.

In the event of the service being disabled, the correct payment of the section toll is only possible if the digital section toll FLEX service is reactivated in the personal user account "My account" or an alternative payment option is used.

Before each journey, the driver must ensure that the vehicle license plate has been registered for the digital section toll FLEX service by querying the vehicle licence plate in the vignette registry.

4.2.3 Procurement from ASFINAG vending machines

The range of products is limited at the ASFINAG vending machines. They are freely accessible. Further information on the locations of the ASFINAG vending machines and the products offered there is available on the internet at <https://www.asfinag.at/vertriebsstellen/>.

In regard to the start of validity and the required details, the regulations mentioned in Part A I, items 3.2.2.1 and 3.2.2.2 are in corresponding effect.

4.2.4 Purchase at points of sale

Selected single-trip tickets (item 3.2.1), as well as multi-trip cards (item 3.2.3) can be purchased at certain points of sale. Further information is available on the internet at <https://www.asfinag.at/vertriebsstellen/>.

In regard to the start of validity and the required details, the regulations mentioned in Part A I, items 3.2.3.1 and 3.2.3.2 are in corresponding effect.

4.2.5 Means of payment

Payment in the ASFINAG toll shop and at ASFINAG vending machines must be made exclusively in euros (EUR). Information on which payment methods and means are permitted in the ASFINAG toll shop and at ASFINAG vending machines is contained in Appendix 2 (available at <https://www.asfinag.at/mautordnung>) and can be obtained from the ASFINAG Service Center (see item 1.5).

The accepted means of payment at points of sale can differ, depending on the point of sale and should be requested from the point of sale in question.

4.3 ADDITIONAL SERVICES (“My Account”)

4.3.1 General services

In the toll shop, it is possible to create a personal user account ("My Account") at any time (i.e. even after completion of the purchase process) by entering access data. The regulations of Part A I, item 3.2.5.1 apply accordingly.

4.3.2 Digital subscription in the personal user account ("My Account")

It is possible to take out a digital subscription in the ASFINAG toll shop, which is a subscription for an indefinite period for procurement of a multi-trip card (item 3.2) in the following years, to manage it (for example keeping credit card details up to date) and to cancel it.

If a digital subscription for a digital annual card was taken out before 1 December 2023, the customer will receive a multi-trip card as a follow-up purchase in the following years after the expiry of the validity of the annual card.

The regulations of Part A I, item 3.2.5.2 apply accordingly to digital subscriptions, with the following distinctive features, regardless of when they are taken out:

- **Validity:** When purchasing a multi-trip card for the first time (= initial acquisition) customers can select the first day of validity for the multi-trip card in accordance with Part A I, item 3.2.1.1. Subsequent purchases of the multi-trip card within a digital subscription follow on seamlessly from the validity period for the currently valid multi-trip card and are determined by the first day of validity for the multi-trip card as selected by the customer.

Example: A customer purchases a multi-trip card and decides to take out a digital subscription as well. The customer chooses the 28 September as the first validity day for the multi-trip card when purchasing the first card. September. The last day of validity of this initial purchase is therefore 27 September of the following year. The first day of validity of a subsequent purchase is 28 September of the following year.

- **Information for the customer:** An e-mail address is required for the procurement of the digital subscription. At least 20 days before payment is collected, the customer receives information, particularly on the date of the upcoming collection of payment (debit of the acquisition price of the multi-trip card), the amount to be collected and the last possible date by which cancellation of the digital subscription for subsequent payments is possible. This e-mail address is also used to inform the customer whether collection of payment was successful.

- *Successful debit:* Following successful debit and thus the procurement of a multi-trip card, the customer is informed via the e-mail address specified by the customer and sent the order confirmation and invoice for the transaction. In this case the multi-trip card is valid as from the day following the last day of validity of the previous multi-trip card.
 - *Unsuccessful debit:* The customer is also informed about this via an e-mail to the e-mail address specified by them. If the debit can't be successfully carried out (for example because the credit card specified is no longer valid), this counts as timely cancellation of the digital subscription. In this case, the entitlement to use toll roads ends on the last day that the existing multi-trip card is valid.
- Cancellation of the digital subscription: Cancellation of the digital subscription can be made in the personal user account ("My Account") at any time and without giving reasons.

4.3.3 Retrospective payment of single trip (digital section toll FLEX) in the personal user account ("My Account")

In the ASFINAG toll shop it is possible to set up the payment of single trips retrospectively (digital section toll FLEX). Within the framework of the digital section toll FLEX, a payment method accepted by ASFINAG (see Appendix 2) is stored for one or more motor vehicle registration numbers and the respective rate for single trips (item 3.2.1) is paid retrospectively by this payment method (digital section toll FLEX). The ASFINAG toll shop can be used to register motor vehicle registration numbers for the digital section toll FLEX service, to manage the registration (for example to update credit card data) and to cancel the digital section toll FLEX service.

The accepted options and means of payment are mentioned in Appendix 2.

4.4 Terms of use

Further information on the procurement of the digital section toll via the ASFINAG toll store, the purchase of the digital subscription and the payment option digital section toll FLEX, the information required for this and the steps to be taken, as well as the other services, can be found in the respective terms of use, available at <https://shop.asfinag.at>.

In addition, upon request, the current Tolling Regulations and the data privacy policy (www.asfinag.at/privacy) may be inspected at points of sale at any time.

4.5 RIGHT OF WITHDRAWAL

If the digital section toll is purchased by consumers by means of long distance selling, i.e. via the ASFINAG toll shop or an authorized online sales partner, withdrawal is possible within 14 calendar days from the day on which the digital section toll was procured, without giving reasons

In order to exercise the right of withdrawal, ASFINAG must be informed of the decision to withdraw from the subscription by means of a clear statement. The withdrawal period shall be respected when the withdrawal notice is sent within the deadline.

For single trips, there is no right of withdrawal once the single trip has started (passage through the toll station) if the customer requests early fulfilment of the contract for the single trip in the ASFINAG toll shop or from an authorized online sales partner. This shall also apply to single trips which are processed and paid for using the digital section toll FLEX (item 4.2.2 or 4.3.3).

If early fulfilment of the contract was expressly requested when purchasing a multi-trip card in the ASFINAG toll shop, a pro rata fee must be paid for the use of the toll section prior to cancellation.

There is no right of withdrawal in the event of purchase at a ASFINAG toll station, point of sale or at an ASFINAG vending machines. This also applies if a multi-trip card is purchased as a follow-on purchase as part of a digital subscription.

More detailed information on the declaration of withdrawal as well as on the refund of payments made is available in the terms of use on the internet at www.asfinag.at.

4.6 SPECIFICS FOR ENTREPRENEURS

The provisions of Part A I, item 3.4 apply equally to companies who receive the digital section toll as part of their activities as a company.

4.7 POSSIBLE CHANGES

In the case of a single trip, the vehicle licence plate and its country of registration as registered in the toll system, can be changed before using the section toll section.

In the case of the multi-trip card, the vehicle license plate registered in the toll system and its country of registration can also be changed before the start of validity. Furthermore, the first day of validity can also be changed, whereby the following must be taken into account:

- The first day of validity may not be changed to a day in the past – at the time of the change
Example: A multi-trip card with a start of validity date of 1 April was procured. If the first day of validity of this multi-trip card is changed on 25 March, it should be noted that the new start of validity may not be postponed to 24 March or earlier (i.e. into the past).
- It is generally possible to change the start of validity to the day on which the change is made, but authorization to use the section toll segment is only granted at the time the change is made.
Example: If today at 14:07 the start of validity of a multi-trip card is changed to today, the permission to use the section toll segment starts at 14:07. Use of the section toll segment before this time with reference to this multi-trip card is not permitted and constitutes toll evasion.
- The first day of validity can only be changed within the calendar year.
Example:
Possible: Postponement from 1 April to 1 October of the same calendar year.
Not possible: Postponement from 1 October of the current year to 1 February of the following year. It is also not possible to postpone from 1 February to 1 October of the previous year.

The permissible changes defined at the beginning can be made as follows:

- In the ASFINAG toll shop (after the registration and login) in the personal user account (see item 4.3)
- Via the ASFINAG Service Centre, at ASFINAG toll stations or at the point of sale where the digital section toll was procured, by presenting the order confirmation or product ID, a copy of the registration certificate of the motor vehicle whose vehicle license plate number is currently registered and - if the vehicle license plate number has changed - the registration certificate of the vehicle whose license plate is to be registered.
- At the ASFINAG toll station by presenting the order confirmation or product ID or toll card and the registration certificate of the motor vehicle whose license plate number is currently registered and - if the license plate number has changed - the registration certificate of the motor vehicle whose license plate number is to be registered.

In case of doubt, ASFINAG or the point of sale shall be entitled to demand further evidence.

4.8 RE-REGISTRATION FROM THE BEGINNING OF VALIDITY

4.8.1 Re-registration without giving reasons

Registration certificate holders are entitled to, without giving reasons, request re-registration to another licence plate number assigned to them in case of a multi-trip card once during its validity period (see item 3.2.2) and in case of the digital section toll FLEX service once per calendar year (1.1. to 31.12.).

A fee of EUR 18.00 including VAT must be paid as reimbursement of expenditures as a prerequisite for re-registration. Regarding the possible payment methods see Appendix 2. For a successful re-registration in the ASFINAG toll shop, the following verification documents must be uploaded or presented at the ASFINAG toll stations, at selected points of sale offering this service or at the ASFINAG Service Center:

- Copy of the registration certificate of the vehicle whose licence plate is currently registered and
- Copy of the registration certificate of the vehicle whose licence plate is to be registered

By re-registering a multi-trip card and/or the digital section toll FLEX service without giving reasons, the registration holder confirms that the one-off option of re-registration without giving reasons has been exercised. Subsequent submission of any documents that serve as proof of authorisation for re-registration in certain cases (see item 3.6.2) is not possible.

A further re-registration of the multi-trip card during the validity period and/or within one calendar year in the event of a re-registration of the digital section toll FLEX service is only possible in the cases specified in item 4.8.2. The re-registration must be carried out before the next use of the section toll segment with the other vehicle licence plate assigned to it. Once the multi-trip card and/or the digital section toll FLEX service has been re-registered, the authorization of the previously registered vehicle licence plate number to use the section toll segment expires.

Re-registration is possible in the ASFINAG toll shop (after registration and login) in the personal user account and at ASFINAG toll stations, as well as at selected points of sale that offer this service.

If the re-registration of a multi-trip card and/or the digital section toll FLEX service is requested in the ASFINAG toll shop, this is a conditional re-registration (see Part A I, item 3.6.3).

For annual cards purchased before 1 December 2023, re-registration is possible without giving reasons until the end of their validity and the requirements specified in this point for multi-trip cards apply accordingly.

4.8.2 Re-registration in certain cases

In addition to the possibility of re-registration mentioned in item 4.8.1, a re-registration of the motor vehicle's license plate registered in the toll system to a newly assigned vehicle license plate of the same holder of the registration certificate can only be requested in the following cases for multi-trip cards after they become valid and/or for the digital section toll FLEX service:

- The holder of the registration certificate changes their place of residence and receives, due to the therefore necessary new vehicle registration, a newly assigned vehicle license plate number. (This is the case, for example, when somebody changes their residence to another administrative district).
- The holder of the registration certificate receives a newly assigned license plate number due to the theft of their motor vehicle.
- The holder of the registration certificate is assigned a new license plate following the theft/loss of the license plate of their motor vehicle.
- The registration holder will be assigned a new registration number to the newly registered motor vehicle due to damage to their motor vehicle as a result of an accident or force majeure which makes it impossible to participate in road traffic with this motor vehicle (total loss).
- The registration holder receives a personalized license plate number.
- After waiving the personalized license plate number or after the personalized license plate has expired, a new license plate number is assigned to the holder of the registration for their vehicle.
- After the delivery of a license plate that is no longer permanently legible, the registration holder is assigned a new vehicle license plate number in accordance with § 50 Para. 2 KFG.
- The registration holder is assigned a new vehicle license plate number as a result of the issue of a license plate pursuant to § 49 para. 4 no. 5 KFG for motor vehicles with pure electric drive or with hydrogen fuel cell drive.
- In "similar cases" to the above mentioned in accordance with section 11(5) BStMG (Federal Road Toll Acts).

Re-registration must be completed before the next use of the section toll segment with the newly assigned vehicle license plate number. Once the multi-trip card and/or the digital section toll FLEX service has been re-registered, the authorization of the previously registered vehicle licence plate number to use the section toll segment expires.

For annual cards obtained before 1 December 2023, re-registration is possible in the aforementioned cases until the end of their validity and the provisions stated in this point for multi-trip cards apply accordingly.

4.8.3 General provisions for re-registration

The provisions of Part A I, item 3.6 on the evidence to be submitted, on conditional re-registration in the ASFINAG toll shop, on re-registration via the ASFINAG Service Centre and on re-registration at ASFINAG toll stations and selected points of sale apply accordingly.

It is expressly pointed out that the payment of an amount of EUR 18.00 including VAT must also be made for the re-registration of a multi-trip card and/or the digital section toll FLEX service in the ASFINAG toll shop upon application. In the cases mentioned in Part A I, Item 3.6.1, this amount will be refunded if the verification test is positive.

In the event of re-registration due to a newly assigned vehicle license plate number as a result of a change of residence, assignment or expiry of the personalised plates, renunciation of the personalised plates, in cases comparable to these facts, as well as in the event of a re-registration without giving reasons, and in the event of a negative verification of evidence, the amount of EUR 18.00 including VAT will be definitively retained as reimbursement of expenditures and will not be refunded.

Furthermore, in the cases mentioned above, re-registration is also possible at the ASFINAG toll stations (see item 1.3.1) or at selected points of sale. The relevant provisions of Part A I, item 3.6.5 apply accordingly.

For re-registration, a copy of the toll card or the order confirmation or product ID as well as evidence that the requirements for re-registration have been met from the date of validity of the multi-trip card and/or the digital section toll FLEX service (see Part A I, item 3.6) must be handed over on site at the ASFINAG toll station or presented at the selected points of sale that offer this service.

In the case of a newly assigned vehicle license plate number due to a change of residence, assignment or expiry of the personalised plate or renunciation of the personalised license plate number, as well as in the event of a re-registration without giving reasons, a reimbursement of expenditures of EUR 18.00 must be paid at the ASFINAG toll station or at the selected points of sale. In all other cases a re-registration can be made at no cost (see also Part A I, item 3.6).

The requested re-registration becomes effective after a positive verification of evidence and from this time on entitles the holder to use the road network subject to tolls with the new vehicle license plate number. The multi-trip card and/or the digital section toll FLEX service for the previous licence plate number expires at this time.

The ASFINAG toll station or point of sale will issue an order confirmation of the re-registration of the vehicle license plate. The customer must check the order confirmation to ensure that the data entered there (in particular the registered vehicle license plate number and the validity period of the multi-trip card) are entered correctly. Any need for correction must be reported immediately to the ASFINAG toll station or point of sale.

It is expressly pointed out that - if the road network subject to mandatory vignette is also used to access the ASFINAG toll station or the distribution partner offering this service - the toll payment for the use of motorways and expressways subject to mandatory vignette must always be made in full compliance with the provisions of Part A I. Failure to do so constitutes toll evasion as defined in Part A I, item 1.9.

For annual cards purchased before 1 December 2023, the provisions set out in this item for multi-trip cards apply accordingly.

4.8.4 Re-registration of the digital vignette and the digital section toll

If both a digital annual vignette and one or more multi-trip cards or the digital section toll FLEX service are registered to a licence plate number, the above provisions apply mutatis mutandis. If

the re-registration of several products registered to the same licence plate number (digital annual vignette, multi-trip card, digital section toll FLEX service) is applied for in one application, a possible reimbursement of expenditures of EUR 18.00 is only payable once.

For annual cards (Part AII, item 3.2.2) purchased before 1 December 2023, the provisions set out in this section for multi-trip cards apply accordingly.

5 DATA PROTECTION AND DATA SECURITY

ASFINAG is entitled pursuant to § 16a BStMG (Federal Road Toll Acts) to process the personal data required for toll collection, toll collection and the prosecution of toll evasion with the aid of automation. Furthermore, ASFINAG is also entitled to process personal data which is required for the vignette registry (see item 1.1) in accordance with section 16b BStMG (Federal Road Toll Acts).

To verify if the toll has been paid properly and to trace toll evasion, in accordance with section 19a BStMG (Federal Road Toll Acts), ASFINAG is entitled to use technical equipment. The image data and the vehicle license plate number and control data obtained from it may be processed for the purposes of collecting the toll, requesting payment of a substitute toll or the information letter pursuant to section 30b para. 1 of the BStMG (Federal Road Toll Acts) and prosecuting toll evasion.

More detailed explanations of the data protection principles and information on the rights of data subjects are available online at <https://www.asfinag.at/privacy>.

6 MONITORING CORRECT PAYMENT OF THE SECTION TOLL

6.1 TOLL ENFORCEMENT OFFICERS

The toll enforcement officers are organs of public supervision. They are appointed and sworn in in accordance with the provisions of Section 17 (2) BStMG (Federal Road Toll Acts).



Figure 10a

When discharging their duties, toll enforcement officers must carry with them the identification card defined below and show it to the person concerned when requested to do so. When carrying out their duties, toll enforcement officers must carry the ID card described below and present it to the person concerned on request.



Figure 10b

The toll enforcement authorities' inspection vehicles are motor vehicles of the public security service pursuant to § 20 Para. 1 No. 4 lit a KFG 1967. These vehicles are silver-grey operational vehicles that are equipped with flashing blue lights and a siren. They are also marked with the following inscriptions: "ASFINAG", "Toll monitoring" and "ASFINAG Service and Control Service" (see Figure 11).



Figure 11

For the purpose of checking the proper payment of both the time-based toll and the section toll, the toll enforcement officers are authorized, among other things, to request motor vehicle drivers to stop by means of clearly visible or audible signs, to stop them, to establish the identity of the driver and the registration holder, to inspect the motor vehicle (in particular the registration certificate, in the case of trips with test drive or transfer license plates within the meaning of item 1.2), to inspect the weight of the motor vehicle (in particular a copy of the type certificate), to inspect the vehicle (in the case of trips with test drive or transfer license plates within the meaning of item 1.2) and to inspect the motor vehicle (in particular a copy of the type certificate). the registration certificate), in the case of trips with test drive or transfer license plates within the meaning of item 1.2, evidence of the vehicle's tare weight (in particular a copy of the type certificate), and to verbally request the driver to pay the replacement toll.

Furthermore, for the purpose of monitoring the proper payment of the toll and carrying out traffic surveys, the toll enforcement officer are authorized to direct motor vehicles to the toll control areas, currently A 1 Eberstallzell, A 1 Haag, A 1 Walserberg, A 2 Arnoldstein, A 2 Arnwiesen, A 2 Haimburg, A 2 Ilztal, A 6 Kittsee, A 4 Bruck/Leitha, A 4 Nickelsdorf, A 4 Gols, A 4 Zurndorf, A 5 Schrick, A 8 Kematen, A 8 Suben, A 9 Liesingau, A 9 Liezen, A 9 Schoberpaß, A 9 Straß, A 9 Trieben, A 9 Übelbach, A 9 Windischgar, A 8 Liesingau, A 9 Liezen, A 9 Schoberpaß, A 9 Strass, A 9 Trieben, A 9 Übelbach, A 9 Windischgar, A 8 Liesingau, A 9 Liesingau, A 9 Liezen, A 9 Schoberpaß, A 9 Trieben, A 8 Kematen, A 8 Suben, A 9 Liesingau, A 9 Liezen, A 9 Schoberpaß, A 9 Straß, A 9 Trieben, A 9 Übelbach, A 9 Windischgar, A 10 Hoher Göll, A 10 Kellerberg, A 11 Rosegg, A 11 Karawankentunnel, A 12 Roppener Tunnel east portal control bay, A 12 control bay Zirl Ost, A 12 junction Wörgl-Ost, A 14 Hörbranz, A 14 Nüziders, S 4 Pötsching, S 3 Göllersdorf, S 16

Kettenanlegeplatz Bings, S 31 Hirm Nord, S 31 Hirm Süd and S 37 Maria Saal. Additionally, toll enforcement officers may also monitor the correct payment of tolls and conduct traffic surveys at border crossings and junctions.

If no substitute toll is paid and if prosecution or enforcement of the penalty appears to be impossible or considerably more difficult, toll enforcement officers are authorized pursuant to § 27 BStMG (Federal Road Toll Acts) to collect a provisional security deposit or, as long as the provisional security deposit is not paid, to order the interruption of the trip pursuant to § 28 BStMG (Federal Road Toll Acts) and to prevent its continuation by taking suitable precautions (removal of the vehicle keys and vehicle documents, installation of technical locks on the vehicle, parking at a suitable location, etc.).

6.2 CONFISCATION OF LICENSE PLATE NUMBER RELATED CARDS

The toll enforcement officer and toll personnel are authorized to confiscate cards with a registration plate if these cards are used for unauthorized motor vehicles.

7 TOLL EVASION

7.1 PENALTY FOR TOLL EVASION AND FOR VIOLATING A DRIVING BAN ORDERED BY THE STVO

Drivers who use routes subject to tolls (section toll segments) in accordance with Part A II without properly paying the toll owed are committing an administrative offence that is considered toll evasion within the meaning of Section 20 (1) BStMG (Federal Road Toll Acts). The administrative offence is punishable by the district administrative authority with a fine of EUR 300.00 to EUR 3,000.00. Drivers who have duly paid the toll but violate a driving ban imposed under the StVO are committing an administrative offence under the StVO. It should be noted that motor vehicles with a maximum technically permissible laden mass of more than 3.5 t, which are covered by the transitional rule pursuant to Section 33 para. 18 Z 8 BStMG (Federal Road Toll Acts), are deemed to be motor vehicles with a maximum technically permissible laden mass of no more than 3.5 t until 31 January 2029.

Examples of such administrative offences are:

- The driver of a motor vehicle with a maximum technically permissible laden mass of no more than up to and including 3.5 t uses an open lane of the Bosruck and/or Gleinalm toll stations on the A 9 (see item 2.2.2.2 "Open lane operation on the A 9") or the open lane of the Schönberg toll station on the A 13 (see item 2.2.2.3 "Open lane operation at the Schönberg A 13 toll station") without having duly paid the toll.
- The driver of a motor vehicle with a maximum technically permissible laden mass of no more than 3.5 t uses a toll section although the digital section toll FLEX service is disabled for the license plate of the motor vehicle and the driver does not pay the toll properly in any other way.
- The driver of a motor vehicle with a maximum technically permissible laden mass of no more than 3.5 t uses the open lane, which is only open to motor vehicles with a maximum technically permissible laden mass of over 3.5 t (see item 2.2.2.1 "Open toll lane operation on A 10, A 11 and S 16"). According to the German Road Traffic Regulations (StVO), driving

in this lane is prohibited for motor vehicles with a maximum technically permissible laden mass of no more than 3.5 t.

If the driver has used the open toll lane without having paid the toll properly, i.e. he does not have a valid digital section toll authorisation or has not properly paid the toll as part of the digital section toll FLEX service (see item 4.2.2), he is committing an administrative offence which is considered toll evasion within the meaning of § 20 para 1 BStMG (Federal Road Toll Acts). In this case, the driver is only punished according to the provisions of the BStMG (Federal Road Toll Acts), but not according to the provisions of the StVO.

If the driver has used the open toll lane but paid the toll properly, i.e. he has a valid digital section toll authorization or has properly paid the toll as part of the digital section toll FLEX service (see item 4.2.2), the violation of a driving ban imposed by the StVO for motor vehicles with a maximum technically permissible laden mass of up to and including 3.5 t will be reported to the district administrative authority.

7.2 NON-IMPOSITION OF A PENALTY

A penalty as per the provisions of the BStMG (Federal Road Toll Acts) is not imposed if a substitute toll – as described below (item 7.3) – is paid. Any substitute toll duly paid in accordance with § 19 BStMG (Federal Road Toll Acts) cannot be reclaimed (§ 20 para 6 BStMG (Federal Road Toll Acts)).

7.3 SUBSTITUTE TOLL

7.3.1 Method of payment

The substitute toll may not be paid in instalments. If partial payments are received, these will be refunded after deduction of a processing fee of EUR 15.00 (including 20% VAT). This also applies to late payments after a report has been made to the competent district administrative authority, payments without the correct identification number stated as the payment reference, and payments to an account other than the one stated on the copy of the request for payment of the substitute toll or the information letter pursuant to Section 30b (1) BStMG (Federal Road Toll Acts). In the event of overpayments up to and including EUR 5.00, no money will be credited to the payer's account (otherwise the entire amount will be credited to the payer's account).

7.3.1.1 Request by toll enforcement officers

Toll enforcement officers are authorized to verbally request the motor vehicle driver (if necessary also as representative of the registration holder in accordance with § 19 para. 5 BStMG (Federal Road Toll Acts)) to pay a substitute toll. The substitute toll shall be paid immediately upon request by the toll enforcement officer in cash or by the payment method specified in Appendix 2. The vehicle driver shall be issued with a confirmation of the payment made.

7.3.1.2 Retrospective summons process

If a violation is discovered by means of automatic checks without the driver being apprehended in person, the/a registration holder may receive a written request to pay the substitute toll.

In cross-border procedures, the request for payment of the substitute toll is made in the form of an information letter in accordance with section 30b para. 1 of the BStMG (Federal Road Toll Acts), which is listed as a template in Appendix 8 to the Tolling Regulations.

In addition to the amount of the substitute toll to be paid, the written request also contains an identification number, which is stated as the payment reference, and the bank details.

The substitute toll must be transferred to the account specified in the request for payment or the information letter pursuant to Section 30b (1) BStMG (Federal Road Toll Acts), stating the identification number specified in the request, which is stated as the payment reference. The request to pay the substitute toll will be complied with if it is credited to the specified account within four weeks of the request being issued and the transfer order contains the complete and correct identification number, which can be read automatically and is stated as the payment reference.

In the case of the A9 and A13, the information letter can be supplemented by a QR code for retrieving evidence images (see Figure 12).

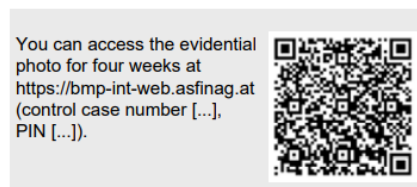

Figure 12

7.3.2 Substitute toll rate

The substitute toll rates (including 20% VAT) for non-payment of the required toll are given below:

Vehicle category	Substitute toll rate
A (single-track motor vehicles)	EUR 65.00
B (multi-track motor vehicles with a maximum technically permissible laden mass of no more than 3.5 t)	EUR 120.00

If the digital annual card or multi-trip card was not re-registered before using a section toll segment with the motor vehicle subject to toll obligation, the following conditions apply:

If improper payment of the toll is discovered and the driver of the motor vehicle is requested in writing by toll supervisory bodies or the registration holder to pay the substitute toll by ASFINAG, the driver/registration owner can, after receiving the request to pay a substitute toll or an information letter, in accordance with Section 30b Paragraph 1 BStMG (Federal Road Toll Acts) Contact the ASFINAG Service Centre and, upon presentation of suitable evidence, they will re-register with the new vehicle license plate to be registered if the requirements for re-registration of the digital annual card or multi-trip card or the digital section toll FLEX service are met in accordance with item 4.8.

In this case, with the proper payment of a substitute toll, the section toll for the section toll segment used for the vehicle license plate that was reassigned to the registration holder is paid retrospectively for the period between the day of the first administrative offence with the

reassigned vehicle license plate and the day of the re-registration. In this case, the amount of EUR 18.00 for re-registration (see item 4.8) is not payable or will be refunded.

If the use of a section toll segment subject to tolls by a motor vehicle subject to tolls is established several times within 30 days without the toll having been properly paid, ASFINAG will issue requests for payment of a substitute toll, or send information letters pursuant to Section 30b (1) BStMG (Federal Road Toll Acts) for a maximum of three cases of toll evasion. For any cases of toll evasion on the same section toll segment exceeding this amount, no substitute toll is payable and these cases will not be reported to the district administrative authority.

7.3.3 Continued journey

Payment of the substitute toll entitles the driver to use the (improperly paid) route subject to toll obligation on the day of entry or inspection by the toll enforcement officers, on the day of the administrative offence determined by automatic monitoring and on the following calendar day.

The receipt issued by the toll enforcement officers is evidence of payment for the substitute toll. If, on the other hand, the substitute toll is not paid despite a request to do so when the toll enforcement officers enter or inspect the road, the toll section must be exited immediately via the next possible exit (regardless of the further course of the route subject to toll obligation).

In the event of non-compliance, the offence of toll evasion shall be committed.

7.3.4 Payment of the substitute toll

Substitute tolls must be paid in euros (EUR). Details about the accepted payment methods and instruments for the substitute toll with toll enforcement officers are outlined in Appendix 2 (accessible at <https://www.asfinag.at/mautordnung>) and are also available through the ASFINAG Service Centre.

8 VIOLATION OF THE OBLIGATION TO STOP

Drivers who fail to comply with a request to stop by a toll enforcement officer contrary to § 18 para. 2 BStMG (Federal Road Toll Acts) commit an administrative offence pursuant to § 21 BStMG (Federal Road Toll Acts) and are liable to a fine of up to EUR 3,000.00.

PART B: TOLL REGULATIONS FOR MULTI-TRACK MOTOR VEHICLES WITH A MAXIMUM TECHNICALLY PERMISSIBLE LADEN MASS OF MORE THAN 3.5 T

1 GENERAL INFORMATION

The distance-based toll is collected using a fully electronic toll system.

The entire road network subject to tolls is divided into individual toll sections, with the toll being collected separately for each individual toll section. The distance-based toll serves to offset infrastructure costs, as well as the costs that arise from traffic-related air pollution, noise pollution and, from January 1, 2024, CO₂ emissions.

In the Tolling Regulations, CO₂ emissions are taken into account before this time, as a declaration of the CO₂ emission class is permitted before January 1, 2024 (see item 5.2).

The prerequisite for proper toll payment is the carrying of an approved, correctly functioning and permanently and properly attached on-board unit (GO-Box or Split-GO-Box, both hereinafter also referred to collectively as "GO-Box" - see item 5.7.1 Tolling Regulations Part B - or another approved on-board unit - see Part C) in the motor vehicle subject to toll obligation. Basically, antennas (radio beacons) are mounted on steel structures above the roadway between the individual junctions of the road network subject to tolls (so-called toll collection stations or toll gantries - see Figure 13).



Figure 13

When driving through a toll collection station, the on-board unit in the motor vehicle establishes contact with the roadside antennas of the toll collection station using microwave technology and subsequently generates a toll collection (toll transaction or debit for short).

ASFINAG has the right to charge the toll to be paid for individual toll sections in accordance with item 7.3 exclusively by automated means and to refrain from setting up a separate toll collection station for these individual toll sections. The toll section rates that apply to these sections are listed according to category and toll rate group in Appendix 4.

Pursuant to § 4 of the Federal Roads Toll Act 2002 as amended (BStMG (Federal Road Toll Acts)), motor vehicle drivers and registration holders are joint toll debtors.

In the following, the term “customer” applies to the holder of the registration certificate, the driver or a third party attributable to the holder of the registration certificate (for example a dispatcher, secretary or fleet manager).

2 SCOPE OF APPLICATION

The Tolling Regulations Part B apply to all multi-track motor vehicles with a maximum technically permissible laden mass of more than 3.5 t. These are subject to a distance-based toll.

Multi-track motor vehicles that have never been registered for traffic and have test drive or transfer license plates are subject to the distance-based toll if their tare weight is more than 3.5 t. When driving with test drive or transfer license plates, a copy of the type certificate or an order confirmation of the producer or his authorized representative pursuant to § 29 para. 2 KFG regarding the tare weight of the motor vehicle must be carried, which must be presented upon request. If evidence of this kind cannot be presented on request, the multi-track vehicle in question shall be considered a vehicle with a service weight of more than 3.5 t.

Pursuant to § 33 para. 18 line 8 BStMG, motor vehicles with a maximum permissible weight of no more than 3.5 t at the time of use of the toll road network, that were first registered for traffic before 1 December 2023, and for which the maximum permissible weight (MPW) was set at no more than 3.5 t before 1 December 2023, are deemed to be vehicles with a maximum technically permissible laden mass of no more than 3.5 t until 31 January 2029 and are therefore subject to the time-based toll or section toll (see Part A I and Part A II).

3 TOLL OBLIGATION

3.1 Road network subject to tolls

Distance-based tolls must be paid for vehicles that are liable for the toll for use of the motorways and expressways listed and illustrated below:

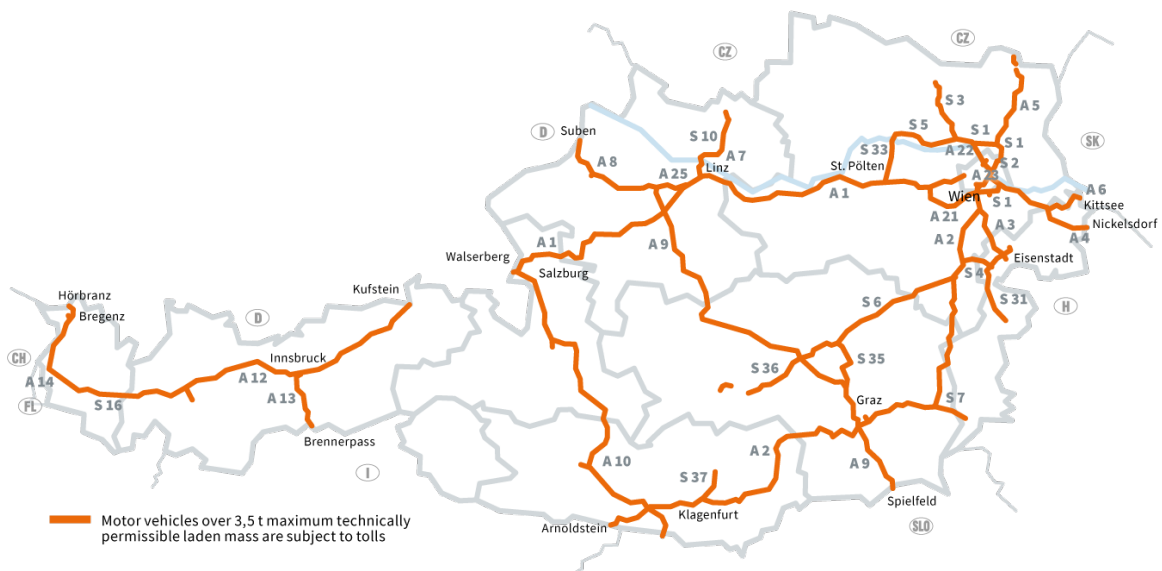

Figure 14

Toll roads in Vienna:



Figure 15

The following motorway or expressway sections are exempt from the obligation to pay a distance-based toll in accordance with the Toll Route Exemption Ordinance of the Federal Minister for Transport, Innovation and Technology as amended by Federal Law Gazette II No. 204/2010:

- S 5 Stockerauer expressway between the Jettsdorf junction (S 33) and the Krems Mitte junction (B 3, B 37).

3.1.1 Areas with existing road tolls

The distance-based toll also applies to the use of motorways and expressways with existing toll stations (A 9, A 10, A 11, A 13 and S 16). Manual payment of the toll at the existing toll stations is not possible for motor vehicles with a maximum technically permissible laden mass of more than 3.5 t.

The existing main toll stations must only be driven through in the lanes marked for this purpose. These lanes can be operated either in so-called open or so-called mixed toll lane operation (depending on the volume of motor vehicles).

3.1.1.1 Mixed toll lane operation

In mixed toll lane operation, the toll lane can be used both by motor vehicles with a maximum technically permissible laden mass of no more than 3.5 t (see Tolling Regulations Part A II) and by motor vehicles with a maximum technically permissible laden mass of more than 3.5 t (see corresponding signposting - Figure 16a below). The barrier in the mixed toll lane opens automatically for vehicles with a maximum technically permissible laden mass of more than 3.5 t, provided that the distance-based toll has been properly paid. If this is not the case, the barrier remains down. The instructions of the toll booth personnel must then be followed without fail. All lanes at subsidiary toll stations are mixed toll lanes. There is therefore no separate signposting regarding lane operation at the subsidiary toll stations on the A 10 (Zederhaus and St. Michael/Lungau) and the A 13 (Zenzenhof, Igls Patsch, Schönberg Stubaital, Matrei Steinach, Nösslach and Brennersee).

3.1.1.2 Open toll lane operation on A 10, A 11 and S 16

In open toll lane operation on the A10, A11, A13 and S16, one lane is open exclusively for vehicles subject to the distance-based toll. This is specially marked (see Figure 16b).

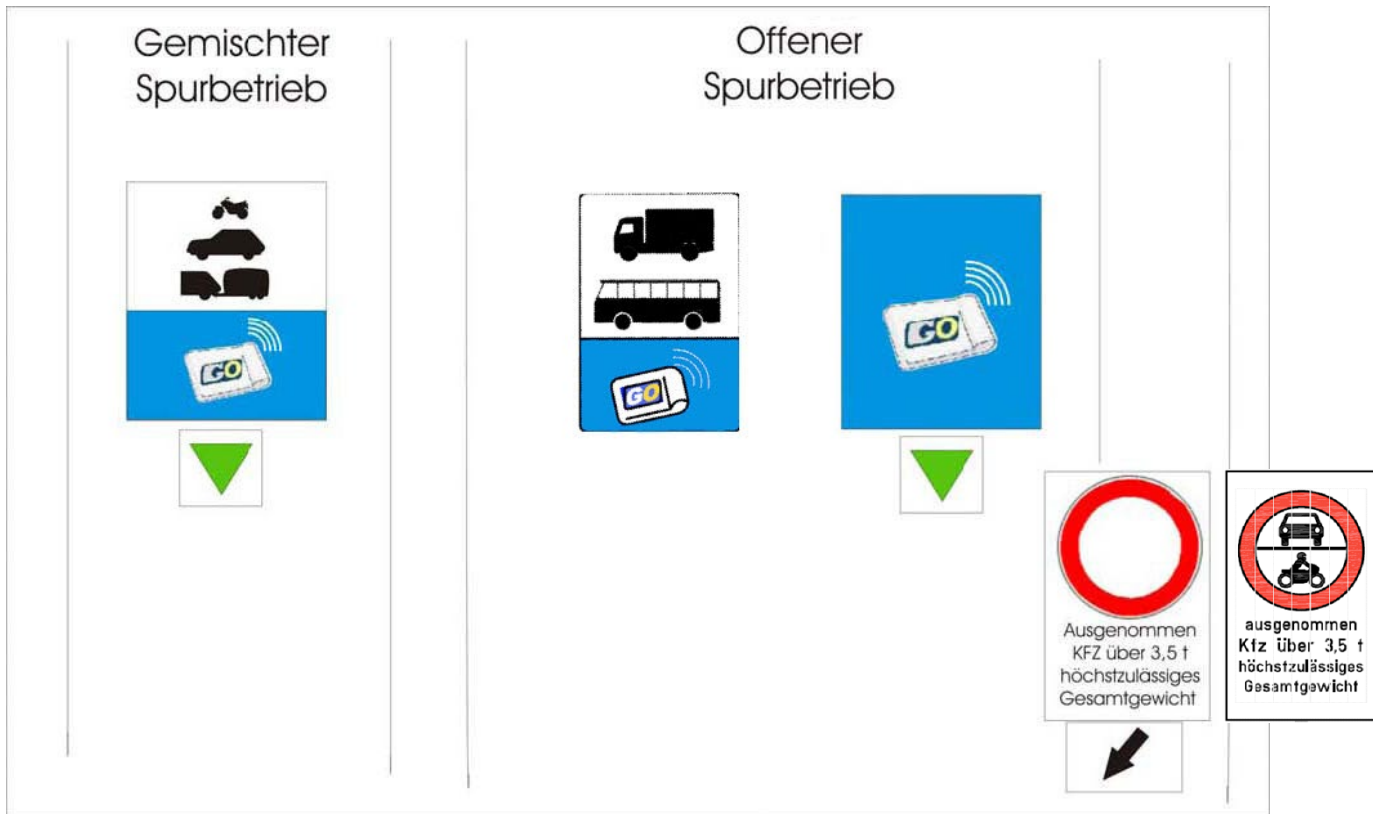

Figure 16a "Mixed track operation"

Figure 16b "Open track operation on A 10, A 11 and S 16"

In open lane operation, there is a driving ban on motor vehicles with a maximum technically permissible laden mass of no more than 3.5 t in accordance with the StVO. The use of this lane by these vehicles is prohibited and constitutes an administrative offence (see Part A II, item 7). It should be noted that motor vehicles with a maximum technically permissible laden mass of more than 3.5 t, which are covered by the transitional rule pursuant to Section 33 para. 18 Z 8 BStMG (Federal Road Toll Acts), are deemed to be motor vehicles with a maximum technically permissible laden mass of no more than 3.5 t until 31 January 2029.

3.1.1.3 Open toll lane operation on the A 9 and at the Schönberg A 13 toll station

In open lane operation at the toll stations on the A 9 motorway (Bosruck, Gleinalm) and at the Schönberg toll station on the A 13 motorway, at least one lane is also open to motor vehicles subject to the distance-based toll. This is specially marked (see Figure 16c).

Like the open lane operation on the A 10, A 11 and S 16, the open lane operation at the toll stations on the A 9 (Bosruck, Gleinalm) and the Schönberg toll station on the A 13 is operated without barriers, with the difference that the open lane operation at the toll stations on the A 9 and the Schönberg toll station on the A 13 is also available for motor vehicles with a maximum technically

permissible laden mass of no more than 3.5 t, whose license plate numbers have a valid digital section toll authorisation for the Bosruck/Gleinalm section toll segment or for the Brenner section toll segment (see Part A II item 1.1 and item 1.3.1) or are registered for the digital section toll FLEX (see Part A II item 4.2.2).



Figure 16c "Open lane operation on A 9 and A 13"

3.1.2 The toll obligation in areas around road works

The toll obligation must be paid in full for areas around road works. The toll obligation must also be paid in full for road works that require traffic to use different lanes or carriageways, or on sections where contraflow systems have been introduced. Motor vehicles on journeys to or from the construction site are also liable to pay the toll.

Only trips made on the carriageways that are closed to traffic are an exception to this rule. This exemption requires that the motor vehicle that is subject to toll obligation is correctly registered with the system in accordance with item 5, and that the GO-Box in the vehicle (both for the pre-pay and post-pay procedures) is deactivated, for example by properly attaching the shield cover that is available from ASFINAG Maut Service GmbH at GO points of sale (see item 5.3) To this end, the cover must be wrapped at least three times around the GO-Box and subsequently closed securely using staples or adhesive tape. If the GO-Box is not deactivated, a toll transaction or debit will occur for system-related reasons. If this happens, the collected tolls will not be refunded.

3.1.3 Temporary entrances and exits in accordance with Section 26 (2) of the Federal Highways Act

The existence of entries and exits in accordance with section 26(2) of the Federal Highways Act 1971 (i.e. temporary entries and exits from the road network subject to tolls in conjunction with infrastructure projects that are being carried out in the public interest) does not affect in any way the toll sections and toll section rates. Depending on the location of the toll collection station on the one hand and the entrances and exits established within a toll section on the other, the toll section rate must be paid in full even if the toll section in question is only partially used - if a toll collection station is used to charge the toll section in question.

3.2 Signage

Information about the obligation to pay tolls is provided at all border crossings on federal and state roads with motor vehicle traffic by means of signs (Figure 17, Figure 18):



Figure 17*



Figure 18*

In addition, information signs at all slip roads to the road network subject to tolls inform drivers of the obligation to pay tolls (Figure 19):



Figure 19*

(* Motor vehicles with a maximum technically permissible laden mass of more than 3.5 t are subject to the GO toll obligation. The toll symbol indicates the toll obligation for motor vehicles with a maximum technically permissible laden mass of no more than 3.5 t (for toll obligation, see Toll Regulations Part A I).

3.3 Exemptions from the toll obligation

3.3.1 Permanent exemptions

The following motor vehicles are permanently exempt from the toll obligation:

- Motor vehicles with visible blue headlights or warning lights in accordance with section 20(1)(4) and (5) of the Motor Vehicle Act 1967 (hereinafter referred to as 'KFG' for short). In the case of motor vehicles pursuant to § 20 para. 5 KFG, an exemption from the toll obligation exists only for the duration of the use of the headlamp or warning light with blue

light and if the conditions and requirements issued pursuant to § 20 para.6 KFG are complied with during use. When returning from an operation in which headlights or warning lights with blue light were used, these vehicles are also exempt from the toll obligation.

- Motor vehicles on which headlights or warning lights with blue lights are visibly attached in accordance with § 20 Para. 5 KFG and which are registered to non-profit organisations whose tasks are carried out by members or employees who work predominantly on a voluntary basis. The regular use of motor vehicles for the purposes of these devices (or a device specified in § 20 Para. 1 No. 4 KFG) is deemed equivalent to a registration if headlights or warning lights with blue light are visibly attached to the motor vehicles in accordance with § 20 Para. 5 KFG. The respective organisation must submit an annual report to ASFINAG by 30 June. The driver must submit a written application by 30 September for the following year, together with appropriate evidence that the conditions laid down in this provision are met and for which motor vehicles the exemption is requested.
- Motor vehicles of fire brigade organisations to which headlights or warning lights with blue light are visibly attached in accordance with § 20 Para. 5 KFG
- Army vehicles (§ 2 para. 1 no. 38 KFG 1967)
- Motor vehicles used in the performance of peace-keeping operations within the framework of an international organisation, the Organisation for Security and Cooperation in Europe or the European Union pursuant to a decision taken under the common foreign and security policy. If non-military motor vehicles are used for these journeys, these motor vehicles are provisionally subject to the distance-based toll. The toll paid for these journeys will be reimbursed by ASFINAG free of charge. The application for refunds must be submitted by the relevant state authorities once the journeys have been completed. Refund applications must be accompanied by evidence that the toll was paid and submitted directly to ASFINAG Toll Service GmbH (see item 14).
- Motor vehicles used within the framework of the Convention between the States Parties to the North Atlantic Treaty and the other States participating in the Partnership for Peace on the Status of Forces ("PfP-SOFA", Federal Law Gazette III No. 136/1998). If non-military motor vehicles are used for these journeys, these motor vehicles are provisionally subject to the distance-based toll. The toll paid for these journeys will be reimbursed by ASFINAG free of charge. The application for reimbursement must be submitted directly to ASFINAG Toll Service GmbH (see Appendix 6b) by the competent state authority after completion of the journeys, together with the relevant evidence.
- Motor vehicles belonging to the public security forces, tax authorities, prison services, and foreign security forces in accordance with section 2(3) of the Police Cooperation Act (Polizeikooperationsgesetz), as well as vehicles belonging to foreign customs and judicial authorities. Confiscated vehicles that use the road network subject to tolls and to which an official tax authority registration number has been attached are not liable for the toll.
- Vehicles belonging to foreign public emergency services, foreign fire brigades or foreign rescue services. Such motor vehicles shall be exempt from the obligation to pay distance-based tolls only if they are fitted with headlamps or warning lights emitting a blue light visibly on the outside and only for the duration of the use of the headlamp or warning light emitting a blue light. When returning from an operation in which headlights or warning lights with blue light were used, these vehicles are also exempt from the toll obligation.

Vehicles that have blue headlights or warning lights visibly attached to the exterior, but are not registered and therefore carry transfer license plates or other equivalent plates and that use the road network subject to tolls are not exempt from the toll obligation.

3.3.2 Time-limited exceptions

3.3.2.1 Exceptions for humanitarian aid transports

In accordance with Section 5 (2) BStMG (Federal Road Toll Acts), ASFINAG may exempt journeys carried out by motor vehicles with a maximum technically permissible laden mass of more than 3.5 t as part of humanitarian aid transports in emergency situations from payment of the toll by supplementing this provision.

A toll exemption for journeys in the context of humanitarian aid transports applies without exception only if there is a reason within the meaning of Section 5 (2) of the Federal Road Toll Act and the specific reason is announced at this point in the toll regulations.

In order to be able to make such a journey without paying the toll (it is not necessary to equip the vehicle with a GO-Box or other authorised on-board unit), the exception application (Appendix 3b) must be completed and duly signed and sent via Mail to ausnahmeantrag@asfinag.at at least 24 hours before using the road network subject to tolls (application available at <https://www.asfinag.at/mautordnung> and at <https://www.go-maut.at>). If no Internet connection is available, the applicant must call the ASFINAG Service Centre (the telephone number is given in item 14 and in the information in item 14). The application is completed by the ASFINAG employee in accordance with the applicant's details and faxed to the applicant, who in turn must duly sign it. In the event of national disasters, ASFINAG reserves the right to grant an exemption from the toll obligation for a period of more than one day. The completed and signed application must be carried during the toll-exempt journey and presented on request as proof of authorisation.

If a GO-Box or another authorised on-board unit is nevertheless carried, the following must be observed: Exemption from payment of the toll requires that a GO-Box is disabled by the customer (see item 5.5.1 and item 5.5.3) for the duration of the toll-exempt journey, for example by proper closure (at least three folds of the packaging opening and subsequent fixing with staples or sticking with adhesive tape) with shielding packaging provided by ASFINAG Toll Service GmbH at the GO points of sale (see item 5.3).

If a used GO-Box or other authorised on-board unit is not deactivated, a toll transaction or debit will occur due to the system. The amounts debited in this way are not automatically refunded.

Currently applicable cases:

The emergency situation due to the armed conflict in Ukraine is considered a case of necessity within the meaning of Section 5 (2) BStMG (Federal Road Toll Acts). The term "humanitarian aid transports" includes journeys for the purpose of transporting goods and merchandise as well as journeys for the purpose of transporting persons who are considered displaced persons within the meaning of the Displaced Persons Ordinance, Federal Law Gazette II No. 92/2022. The toll exemption is unlimited in time and applies from 1 March 2022.

3.3.2.2 Exceptions at the request of the Federal Ministry of the Interior in the context of state crisis and disaster control management or international disaster relief

At the request of the Federal Ministry of the Interior (BMI), journeys made by motor vehicles with maximum technically permissible laden mass of more than 3.5 t as part of state crisis and disaster control management or international disaster relief may be exempted from payment of the toll on an ad hoc basis.

To ensure that such journeys can be made without the obligation to pay the toll (it is not necessary for the motor vehicle to be fitted with a GO-Box or other authorised on-board unit), the BMI must notify ASFINAG of these journeys, listing the license plate numbers of the motor vehicles concerned and stating the expected route and the exemption period, before the toll road network is used.

Written confirmation from the Federal Ministry of the Interior (BMI) of the specific exemption from the toll obligation must be carried in the motor vehicles concerned during the toll-exempt journey and presented on request as proof of authorisation to use the vehicle.

If a GO-Box or another authorised on-board unit is carried, the following must be observed: Exemption from payment of the toll requires that a GO-Box or other authorised on-board unit is disabled by the customer (see items 5.5.1 and 5.5.3) for the duration of the toll-exempt journey, for example by proper sealing (folding the packaging opening at least three times and then securing it with staples or adhesive tape) with shielding packaging provided by ASFINAG Toll Service GmbH at the GO points of sale (see item 5.3).

If the GO-Box is not deactivated, a toll transaction or debit will occur for system-related reasons. In such a case, reimbursement of the debited amounts is excluded.

3.3.3 Special exemptions

Vehicles that are towed away are exempt from the distance-based toll for the duration of the towing process. Neither the axles of the vehicle being towed away, nor the axles of any attached trailers or motorhomes that also have to be towed away increase the category that must be set for the towing vehicle. This exemption requires that a GO-Box located in the towed vehicle (both in the pre-pay and post-pay procedure) is disabled by properly sealing the GO-Box using shielding packaging provided by ASFINAG Toll Service GmbH at the GO point of sales (see item 5.3) (i.e. by folding the packaging opening at least three times and then securing it with staples or sticking it down with adhesive tape). If the GO-Box is not deactivated, a toll transaction or debit will occur for system-related reasons. If this happens, the collected tolls will not be refunded.

Please note that in accordance with section 46(3) StVO 1960, the vehicle being towed away must leave the motorway or expressway immediately at the next exit (junction).

3.4 Relief measures for people with disabilities

Multi-track motor vehicles with a maximum technically permissible laden mass of more than 3.5 t, which are registered to persons with disabilities ("eligible persons") and are not covered by the transitional provision of § 33 para. 18 Z 8 BStMG (Federal Road Toll Acts), are exempt from the distance-based toll if the following conditions are met:

- the motor vehicle is registered to a beneficiary

- the maximum permissible weight (MPW) of the motor vehicle has been set at no more than 3.5 t
- the beneficiary is domiciled or habitually resident in Austria,
- the entitled person is in possession of a disabled person's pass in accordance with § 40 to 47 of the Federal Disability Act, in which the unreasonableness of the use of public transport or blindness is certified,

If more than one motor vehicle is registered to the entitled person, only the motor vehicle that is exempt from the motor-related insurance tax can be exempted from the distance-based toll.

The entitled party must send the following documents to ASFINAG by e-mail to ausnahmeantrag@asfinag.at:

- Copy of the vehicle registration certificate of the disabled pass holder
- Proof of residence or usual abode in Austria
- Copy of the disabled person's pass in which the unreasonableness of using public transport or blindness is documented

In case of doubt, ASFINAG shall be entitled to demand further evidence.

4 TOLL RATES

The toll rates are based on the 2002 Federal Roads Toll Act and the applicable Toll Rate Ordinance. Based on these specifications, the Tolling Regulations set out in Appendices 4 (toll section rate tables) the currently valid (net) toll section rates for each toll section, differentiated according to total costs and costs of traffic-related air pollution, costs of traffic-related noise pollution and costs of traffic-related CO₂ emissions. These calculated toll rates per road section are listed without VAT.

To read the toll rates per road section charts more easily, each toll section is named after the junction respectively intersection according to the signs on those roads on which toll is being charged. The toll rates per road section stay the same in case of road works, temporary relocations or other time related bans of junctions.

In the post-pay procedure, the net toll rates are added up daily for each motor vehicle registration number and for each means of payment deposited (daily total). Based on the daily sum the VAT will be calculated and added which results in the gross-toll rate for the day. For the pre-pay contracts the VAT will be paid when charging the toll amount on the device.

The EURO emission class is a characteristic of the motor vehicle and is determined – on the basis of EU directives – by the limit values for emissions. Compliance with the emission limits of the engine installed in the motor vehicle is the decisive factor in determining a EURO emission class.

The CO₂ emission class is a characteristic of the motor vehicle. The allocation of a vehicle to one of the five CO₂ emission classes is based on the CO₂ emissions of the vehicle in accordance with Article 2(1)(28) of Directive 1999/62/EC as amended (hereinafter referred to as the Eurovignette Directive) in accordance with Article 7ga(2) sentence 1 in conjunction with Article 2(1)(29), (30) and (34) to (38) of the Eurovignette Directive.

CO₂ emission class 1 includes vehicles that cannot be assigned to any other CO₂ emission class. This may be the case in particular if the CO₂ emissions of the vehicle do not justify classification in a different CO₂ emission class or if no suitable evidence is provided in accordance with item 5.2.4. In

addition, vehicles are also assigned to CO₂ emission class 1 if no reference values for CO₂ emissions within the meaning of Article 2(1)(38) of the Eurovignette Directive are available.

CO₂ emission class 2 includes vehicles whose CO₂ emissions are more than 5% below the emission reduction curve within the meaning of Article 2(1)(37) of the Eurovignette Directive, but which do not belong to CO₂ emission classes 3, 4 or 5.

CO₂ emission class 3 includes vehicles whose CO₂ emissions are more than 8% below the emission reduction curve within the meaning of Article 2(1)(37) of the Eurovignette Directive, but which do not belong to CO₂ emission classes 4 or 5.

CO₂ emission class 4 includes "low-emission vehicles" within the meaning of Article 2(1)(30) of the Eurovignette Directive.

CO₂ emission class 5 includes "low-emission vehicles" within the meaning of Article 2(1)(29) of the Eurovignette Directive.

Vehicles assigned to CO₂ emission class 2 or 3 are reassessed and, if necessary, reclassified six years after their first registration and every six years thereafter on the basis of the threshold values applicable at that time. The new CO₂ emission class, if applicable, will take effect no later than six years and one day after the date of first registration of the vehicle concerned.

The following toll rate groups apply:

The following toll rate groups for charging infrastructure costs for category 4 are envisaged:

Toll rate group	Motor vehicle
E	CO ₂ emission class 5
A	other CO ₂ emission classes

The toll section rates for charging the infrastructure costs on the toll sections of the A13 motorway are differentiated by time (day / night). The "night" rate is defined by the time period between 10 pm and 5 am. The time registered in the toll system at the time the vehicle passes the respective toll collection point is decisive when it comes to determining whether the night-time rate applies (the time on the radio-controlled clock is used as a reference).

The following toll rate groups for charging for traffic-related air pollution and traffic-related noise pollution are envisaged:

Toll rate group	Motor vehicle
E	emission-free vehicles
A	EURO emission class VI
B	EURO emission classes V and EEV
C	EURO emission class VI
D	EURO emission classes 0–III

The toll rate groups for charging for transport-related CO₂ emissions are divided into five CO₂ emission classes (1 to 5).

Toll rate group according to CO ₂ emission class	Motor vehicles with
5	CO ₂ emission class 5
4	CO ₂ emission class 4
3	CO ₂ emission class 3
2	CO ₂ emission class 2
1	CO ₂ emission class 1

If a motor vehicle that was classified before 3 January 2009 does not have EURO I-VI classification, the following concordance table applies.

EURO I	Euro 1
EURO II	Euro 2
EURO III	Euro 3
EURO IV	Euro 4
EURO V	Euro 5
EURO VI	Euro 6

Concerning the differentiation of toll rates due to the number of axles the following applies:

The number of axles must include attached lift axles, tandem axles and double axles. Support axles and trailers towed by buses or motorhomes within the meaning of § 2 Para. 1 Z 28a KFG, however, are not to be taken into account when determining the number of axles.

The toll rates for the toll sections specified in Section 10 (2) BStMG (Federal Road Toll Acts) are also determined on the basis of Section 9 BStMG (Federal Road Toll Acts) and the Toll Rate Ordinance.

The following documents must be submitted with the first application:

- Information about the location and time of the passage (individual service information or transaction information [i.e. information about the last 30 transactions stored in the GO-Box] at the GO points of sale)
- Copy of the vehicle registration certificate
- name of account holder and bank account details for the transfer of the refunded amount.

As long as there is no change in the aforementioned data, only the toll section used and the time of passage must be indicated when submitting further refund applications for the same vehicle. The application must be sent by post or fax to ASFINAG Toll Service GmbH (see item 14).

If the journey is carried out using the pre-pay procedure, the driver of the motor vehicle must ensure that the GO-Box has sufficient toll values. Partial non-payment of the toll resulting from insufficient toll credit in the GO-Box shall be treated as a toll evasion offence and incurs all the relevant consequences and penalties.

5 REGISTERING WITH AND DEREGISTERING FROM THE TOLL SYSTEM

5.1 General information

Pursuant to Section 8 (1) BStMG (Federal Road Toll Acts), drivers of motor vehicles subject to tolls are obliged to equip them with authorised on-board units for the electronic payment of the distance-based toll in accordance with the provisions of these Tolling Regulations before using the road network subject to tolls

This obligation includes

- Registration for the toll system (system registration for the post-pay or pre-pay procedure - see item 5.5),
- the acquisition of an approved vehicle device and
- and the permanent, proper attachment of this unit to the vehicle that is subject to toll obligation (see item 8.1).

There are no plans for other forms of toll collection. Retrospective payment of the toll is only possible in certain circumstances (see items 7.1 and/or 7.2). The vehicle registration certificate for the vehicle that is liable for the toll must be presented for registration with the toll system.

Only the following on-board units are authorised for electronic toll collection:

- ASFINAG on-board units: the GO-Box or the Split-GO-Box (see item 5.7)
- Explicitly authorised on-board units from toll operators of foreign toll systems (see Part C). Transferors who use such an authorised on-board unit are not subject to the special regulation of item 5.6.6.

5.2 Declaration of rate-relevant characteristics (CO₂ emission class, EURO emission class)

Motor vehicles are always assigned to the highest toll rate group. For this purpose, CO₂ emission class 1 and/or EURO emission class I are stored in the toll system for the respective vehicle licence plate, unless the entry of a better CO₂ emission class and/or a better EURO emission class was or is expressly requested (hereinafter referred to as "requested rate-relevant characteristics").

To help customers determine the CO₂ emission class of their vehicle, ASFINAG provides a CO₂ emission class calculator (available at: <https://go-maut.at/co2-rechner>). By entering the drive type, the vehicle's date of first registration, the vehicle group and vehicle subgroup and the specific CO₂ emissions of the vehicle, the CO₂ emission class is determined on the basis of the values entered and displayed as a result for information purposes only.

However, the use of the CO₂ emission class calculator by the customer does not constitute a declaration of rate-relevant characteristics within the meaning of these Tolling Regulations.

An explicit declaration of a different CO₂ emission class and/or a different EURO emission class can be made either

- by presenting the GO box assigned to the motor vehicle registration number at a GO point of sale or
- by submitting the complete verification documents of the vehicle's rate-relevant characteristics (see also item 5.2.3).

For motor vehicles that belong to CO₂ emission class 1 and at the same time to EURO emission class 0, I, II or III, a declaration at the GO point of sale or evidence of the rate-relevant characteristics is not required.

A specific CO₂ emission class and/or a specific EURO emission class must be expressly requested at a GO point of sale, not only when declaring the rate-relevant characteristics, but also when registering for the toll system or when changing data (see item 5.6); otherwise CO₂ emission class 1 and EURO emission class I will be deposited. For this purpose, it is necessary to present the GO-Box at the GO point of sale.

The legality of the deposit of the required rate-relevant characteristics is not checked at the GO point of sale and cannot be proven at the GO point of sale. However, the legality of the required rate-relevant characteristics must be proven to ASFINAG either in advance (see item 5.2.3.2) or afterwards (see item 5.2.3.1) by means of appropriate verification documents. The explicitly required rate-relevant characteristics are stored in the toll system and are therefore directly relevant to the rate.

An entitlement to be charged the toll rate assigned to the respective toll rate group only arises if either

- the registration of the rate-relevant characteristics (CO₂ emission class, EURO emission class) is requested by presenting the GO-Box at a GO point of sale (and is thereby deposited in the toll system) and the verification of evidence (evidence of the legality of the requested rate-relevant characteristics) was subsequently completed positively; with regard to the registration deadline, reference is made to item 5.2.3, or
- the verification of evidence for the rate-relevant characteristics was carried out positively by sending the complete verification documents for the rate-relevant characteristics specific to the motor vehicle. (Item 5.2.3).

A vehicle declaration is issued at the GO point of sale after each filing of a rate-relevant characteristic, which shows the

- contract type (post-pay / pre-pay)
- the official motor vehicle registration filed on the GO-Box
- the GO-Box identification number (= on-board unit number) deposited on the GO-Box
- the number of axles of the towing vehicle
- and the filed rate-relevant characteristics (CO₂ emission class and/or EURO emission class).

This vehicle declaration must remain in the motor vehicle in its most recent version.

The latest valid vehicle declaration can be obtained at any time (by presenting the GO-Box) at a GO point of sale. The latest valid vehicle declaration (with the stored rate-relevant characteristics), in addition to the possibility of immediate printing at the GO points of sale, also

- is visible in the SelfCarePortal,
- is accessible by querying the ASFINAG system after identification with the GO-Box identification number and the associated PAN using the following link: <https://www.go-maut.at/fahrzeugdeklaration/>,
- can be requested by calling the ASFINAG Service Centre (see item 14),
- can be found in the itemised toll information sheet (item 6) and
- can be seen on other printouts from a GO point of sale.

In addition, when rate-relevant characteristics are stored, an information document is provided for the stored motor vehicle data, which contains in particular the following information:

- the motor vehicle registration number concerned and the GO-Box identification number,
- Date and time via the rate-relevant characteristics filed at this time (CO₂ emission class and/or EURO emission class) and
- deadlines to be observed by the registration holder, where applicable.

5.2.1 Declaration of the CO₂ emission class

5.2.1.1 Declaration of the CO₂ emission class by the registration holder

For the purpose of declaring the CO₂ emission class, the holder of the registration certificate can request that a specific CO₂ emission class be stored on site at a GO point of sale.

After the CO₂ emission class has been deposited at a GO point of sale, the vehicle declaration is issued. By checking the vehicle declaration which has been issued, the registration holder is to ensure that

- the official motor vehicle registration number stored in the GO-Box is the same as the actual motor vehicle registration number attached to the vehicle and
- the GO-Box identification number of the GO-Box carried corresponds to the GO-Box identification number stated on the vehicle declaration and
- the required CO₂ emission class has been stored in accordance with the declaration of the registration holder.

In the event of a non-compliance, the registration holder must arrange an immediate change at the GO point of sale, otherwise the offence of toll evasion according to item 10 can be fulfilled. This obligation to check also applies to reprints or when a new vehicle declaration is being issued. Generally, the vehicle declaration is to be carried by the driver during the journey (see item 8).

In addition, an information document is handed over, which is also subject to an obligation to check by the registration holder

It is expressly pointed out that - if the motor vehicle is assigned to CO₂ emission class 1 - it is possible to declare the EURO emission class as an (additional) rate-relevant characteristic (see item 5.2.2).

5.2.1.2 Declaration of the CO₂ emission class by a third party designated by the registration holder

The registration holder is entitled to instruct a third party (in particular the motor vehicle driver) to request that a specific CO₂ emission class be deposited on site at a GO point of sale. In this case, the third party acts as a representative of the registration holder and takes over the declaration of the CO₂ emission class for them.

After the CO₂ emission class has been saved at a GO point of sale, the vehicle declaration will also be issued in this case. The third party is to check the vehicle declaration, in order to ensure that

- the official motor vehicle registration number stored in the GO-Box is the same as the actual motor vehicle registration number attached to the vehicle and
- the GO-Box identification number of the GO-Box carried corresponds to the GO-Box identification number stated on the vehicle declaration and

- that the CO₂ emission class given to the third party by the holder of the registration holder was stored accordingly.

If the third party notices any discrepancies, they must request that the information be corrected immediately at the GO point of sale. Failure to comply with this provision constitutes a toll evasion offence in accordance with item 10. This obligation to check also applies to reprints or when a new vehicle declaration is being issued. Generally, the vehicle declaration is to be carried by the driver during the journey (see item 8).

The registration holder is responsible for the correctness of the CO₂ emission class declaration. To this end, the registration holder is to promptly request that the third party hands over the customer receipt to the registration holder in order to ensure that the required evidence can be provided in time (see item 5.2.3.).

If the registration holder discovers after handing over the information document that an incorrect CO₂ emission class has been saved, the registration holder must immediately save the correct CO₂ emission class at a GO point of sale or have it saved by a third party. Express reference is made to the possibility of subsequent payment of the toll (see item 7). Refunds will not be given for excess toll payments made in the period before the new CO₂ emission class is entered.

It is expressly pointed out that - if the motor vehicle belongs to CO₂ emission class 1 - the registration holder is also entitled to instruct the third party to request the EURO emission class as an (additional) rate-relevant characteristic (see item 5.2.2).

5.2.2 Declaration of the EURO emission class

If the motor vehicle is assigned to CO₂ emission class 1, it is possible to declare the EURO emission class as an (additional) rate-relevant characteristic at the GO point of sale in order to be assigned to the toll rate groups (see item 4, toll rates) according to this characteristic of the motor vehicle.

If the vehicle is assigned to CO₂ emission class 2, 3 or 4, EURO emission class VI is (additionally) stored in the toll system as standard for the motor vehicle and taken into account when assigning it to the toll rate groups.

No EURO emission class is stored in the toll system for motor vehicles in CO₂ emission class 5.

5.2.2.1 Declaration of the EURO emission class by the registration holder

The regulations under item 5.2.1.1 on the declaration of the CO₂ emission class by the registration holder (in particular the obligation to test and the associated rules of conduct) also apply equally to the declaration of the EURO emission class .

5.2.2.2 Declaration of the EURO emission class by a third party designated by the registration holder

The regulations under item 5.2.1.2 on the declaration of the CO₂ emission class by a third party appointed by the registration holder (in particular the obligation to inspect and the associated rules of conduct) also apply accordingly to the declaration of the EURO emission class by a third party appointed by the registration holder.

5.2.3 Provision of evidence and verification of rate-relevant characteristics (CO₂ emission class, EURO emission class)

If the deposit of a rate-relevant characteristic (CO₂ emission class and/or EURO emission class) has been requested, the legality of the requested and deposited rate-relevant characteristic must be proven to ASFINAG by means of suitable documents (see item 5.2.4).

The registration holder is informed of the obligation to provide evidence by means of an information document, which is handed over at the GO point of sale in German and - if available - in one of the national languages of the country of registration of the motor vehicle registration number, otherwise in English. If the CO₂ emission class and/or EURO emission class is deposited at the GO point of sale by a third party appointed by the registration holder, the third party must hand over the information document to the registration holder or the registration holder is obliged to request this information document from the third party.

If the required rate-relevant characteristics are to be assigned to the toll rate groups for which the highest rate is set (hereinafter referred to as "highest toll rate groups"), it is not necessary to provide evidence. This is the case for motor vehicles that are assigned to CO₂ emission class 1 and the required EURO emission class (up to and including EURO III) that do not require proof. The omission of the provision of evidence is also indicated by a corresponding information document, which is handed over at the GO point of sale in German and - if available - in one of the national languages of the country of registration of the motor vehicle registration number, otherwise in English.

Evidence of the required rate-relevant characteristics that are not assigned to the highest toll rate groups can

- be provided retrospectively after submission to the GO point of sale (evidence and verification retrospectively, see item 5.2.3.1) or
- in advance before submission to the GO point of sale (evidence and verification in advance, see item 5.2.3.2).

This is certainly the case for the required CO₂ emission classes 2, 3, 4, and 5, as well as for the required EURO emission classes IV, V, EEV, and VI.

5.2.3.1 Retrospective provision of evidence and verification

The verification of evidence is not carried out on site at the GO point of sale, but by ASFINAG. The necessary documents (see item 5.2.4) must be sent to ASFINAG. There are a number of possible ways of doing so:

a) by post

The verification documents must be sent to:

ASFINAG Maut Service GmbH
ASFINAG Service Centre / rate-relevant characteristics
Alpenstraße 99
5020 Salzburg, Austria
Austria

b) *by fax*

The fax number provided for the transmission of the verification documents is:

ASFINAG Maut Service GmbH
ASFINAG Service Centre / rate-relevant characteristics
+43 50 108-912 913

c) *Transmission by e-mail*

The necessary documents may be sent as

- *.pdf
- *.jpg
- *.tif

To euroclass@asfinag.at for examination.

The necessary documents sent by e-mail are considered sent when receipt of the e-mail is confirmed in the form of a response e-mail from ASFINAG to the sender.

d) *Transmission using the SelfCare portal*

All registered SelfCare users have the option of registering the verification documents for their motor vehicles (motor vehicle registration numbers registered for the toll system) via the SelfCare portal, which can be found at: <https://www.go-maut.at/selfcare-portal/>.

The necessary verification documents may be sent in the following formats:

- *.pdf
- *.jpg
- *.tif

be transmitted.

e) *Transmission using the CO₂ emission class calculator*

With the ASFINAG CO₂ emission class calculator, which can be found at <https://go-maut.at/co2-rechner>, it is possible to determine the CO₂ emission class of the vehicle in advance. The verification documents for the respective vehicle can be uploaded to the CO₂ emission class calculator for checking.

The necessary documents may be sent as

- *.pdf
- *.jpg
- *.tif

files.

The verification documents required for the verification of evidence must be submitted to ASFINAG within 30 calendar days (receipt), calculated from the date of deposit of the requested rate-relevant characteristic at a GO point of sale (in any case CO₂ emission class 2, 3, 4 and 5 and, in the

case of CO₂ emission class 1, also if EURO emission classes IV, V, EEV or VI was requested as an (additional) rate-relevant characteristic) to ASFINAG (hereinafter referred to as "registration deadline").

If the submission of the CO₂ emission class was requested before 1 January 2024, the submission period for verification documents relating to the declared CO₂ emission class does not begin until 1 January 2024 and these must be submitted to ASFINAG by 31 January 2024 (receipt) at the latest.

It is not possible to transmit the evidence directly from the GO point of sale.

If the required verification documents are submitted within the registration deadline, ASFINAG will begin the verification of evidence immediately upon receipt of the verification documents.

The test result can be viewed in the SelfCare portal and can also be taken from the final vehicle declaration (see item 5.2). Furthermore, ASFINAG will inform the customer of the test result as far as possible at the e-mail address provided by the customer in the course of the provision of evidence (or - if no such address is available - via another contact address provided). It is also possible to enquire about the processing status and outcome of the verification of evidence at the ASFINAG Service Centre.

5.2.3.1.1 Complete, legible, and timely submission of the suitable documents

If the required and deposited rate-relevant characteristics can be verified on the basis of the verification documents submitted, the verification of evidence is concluded positively. The positive test result can be seen in the SelfCare portal. It is also possible to enquire about the processing status and test result of the verification of evidence at the ASFINAG Service Centre. If the verification check is positive, there is legal certainty with regard to the required and deposited rate-relevant characteristics.

5.2.3.1.2 Incomplete and/or faulty verification documents that have been submitted before the submission deadline

If the necessary verification documents are sent to ASFINAG before the submission deadline, but are found to be faulty (e.g. illegible) or incomplete, ASFINAG will **request a one-off re-submission** of the missing and/or incomplete verification documents.

In order to make it possible for ASFINAG to send such queries or requests, it is essential that the driver provides a valid contact address on the application form.

If it is possible to make a request for re-submission, the submission deadline for submission of the missing and/or incomplete verification documents is extended once by seven days to a maximum total of 37 calendar days.

If the required verification documents are submitted properly and on time following the request by ASFINAG and the legality of the requested and deposited rate-relevant characteristics can be proven on this basis, the verification of evidence is concluded positively. The provisions of item 5.2.3.1.1 shall apply accordingly.

If ASFINAG's request for re-submission is only partially met or not met at all, the verification process is concluded with a negative outcome. In this case, the provisions of item 5.2.3.1.4 shall apply accordingly

If no valid contact address is provided, the verification of evidence is concluded with a negative outcome. In this case, the provisions of item 5.2.3.1.4 shall apply accordingly.

5.2.3.1.3 Timely submission of verification documents for an incorrect CO₂ emission class and/or EURO emission class

If proof documents are submitted within the registration period which prove that an incorrect rate-relevant characteristic was requested and deposited at a GO point of sale, the following differentiation must be made:

a) Assignment of the CO₂ emission class and/or EURO emission class to a toll rate group that requires the payment of a lower toll rate on the basis of the verification documents submitted:

In this case, the registration expiration will not be waited for and the CO₂ emission class and/or EURO emission class verified by the submitted verification documents will be stored in the toll system and the lower toll rate will be applied from this point in time.

It is not necessary to visit a GO point of sale again. There is also no separate signalling by means of signal tones from the GO-Box.

The previous vehicle declaration automatically loses its validity. With regard to the updated vehicle declaration, please refer to item 5.2.

The reimbursement of any difference due to the incorrect declaration of a rate-relevant characteristic is excluded.

b) Assignment of the CO₂ emission class and/or EURO emission class to a toll rate group that requires the payment of a higher toll rate on the basis of the verification documents submitted:

In this case, too, the registration expiration will not be waited for and the CO₂ emission class and/or EURO emission class verified by the submitted verification documents will be stored in the toll system and the higher toll rate will be applied from this point in time.

It is not necessary to visit a GO point of sale again. There is also no separate signalling by means of signal tones from the GO-Box.

The previous vehicle declaration automatically loses its validity. With regard to the updated vehicle declaration, please refer to item 5.2.

The offence of toll evasion pursuant to item 10 may be committed for the period calculated from the time a rate-relevant characteristic is requested at the GO point of sale and until the verification check has been completed, provided that the road network subject to tolls has been used with this motor vehicle and the option of paying the toll in arrears (see item 7) has not been exercised.

c) Deposit of an incorrect CO₂ emission class and/or incorrect EURO emission class within a toll rate group:

In this case, too, the registration expiration will not be waited for and the CO₂ emission class and/or EURO emission class proven by the submitted verification documents will be stored in the toll system and the toll rate corresponding to the characteristics of the motor vehicle (even in the event of any future change in the toll rate group assignment) will be applied.

It is not necessary to visit a GO point of sale again. There is also no separate signalling by means of signal tones from the GO-Box.

The previous vehicle declaration automatically loses its validity. With regard to the updated vehicle declaration, please refer to item 5.2.

5.2.3.1.4 No registration of the verification documents

If no supporting documents (see item 5.2.4) are submitted within the 30-day registration period, the motor vehicle will be assigned to the highest toll rate group (i.e. CO₂ emission class 1 and/or the EURO emission class 0 to III toll rate group) and the highest toll rate will apply from this point in time.

There is no separate signalling by means of signal tones from the GO-Box.

The previous vehicle declaration automatically loses its validity. With regard to the updated vehicle declaration, please refer to item 5.2.

The offence of toll evasion pursuant to item 10 may be committed for the period calculated from the time a rate-relevant characteristic is requested at the GO point of sale and until the verification of evidence has been completed, provided that this motor vehicle is used on the road network subject to tolls and the option of paying the toll in arrears (see item 7.1) has not been exercised.

It is expressly pointed out that a declaration of the rate-relevant characteristics (see items 5.2.1 and 5.2.2) is possible again.

5.2.3.1.5 Late registration of the verification documents

If the verification documents are not submitted in time within the registration deadline, the regulation of item 5.2.3.1.4 shall apply.

Any documents submitted after this point will be considered a new application and the provisions of item 5.2.3 shall apply accordingly.

5.2.3.2 Provision of evidence and verification in advance

Only for motor vehicle registration numbers that have been duly registered for the toll system (active contract) is there the alternative option of submitting verification documents to ASFINAG in advance for checking before actually depositing rate-relevant characteristics at a GO point of sale (see items 5.2.1 and 5.2.2). ASFINAG is not obliged to verify documents submitted by owners of vehicles with registration numbers that do not have a valid toll contract. Nevertheless, ASFINAG is not required to retain any verification documents submitted for possible later use.

The rate-relevant characteristics determined on the basis of the verification documents transmitted are stored in the toll system as a characteristics of the vehicle and the corresponding toll rate is applied from this point in time.

It is not necessary to visit a GO point of sale. There is also no signalling by means of signal tones from the GO-Box.

The previous vehicle declaration thus automatically loses its validity. With regard to the updated vehicle declaration, please refer to item 5.2.

5.2.4 Documents that are suitable as proof of rate-relevant characteristics (CO₂ emission class, EURO emission class)

The following are examples of documents that can be used by the registration holder to provide evidence:

1. The registration certificate (within the meaning of the KFG 1967, Federal Law Gazette I No. 267/1967 as amended) or an equivalent certificate, provided that this certificate was issued by the body authorised to issue it in the country of registration of the motor vehicle.
2. Through the "Customer Information File" (short: "CIF").
3. Through the "Certificate of Conformity" (in short: "CoC document").
4. The "CEMT certificate of conformity with the technical and safety requirements for a motor vehicle" ("CEMT certificate" for short), provided that this certificate was issued by the body authorised to issue it in the country of registration of the motor vehicle.
5. The "Conformity of Production" document (hereinafter referred to as the "CoP document"), provided that this proof has been issued by the body authorised to issue it in the country of registration of the motor vehicle.
6. By a confirmation from the vehicle manufacturer if the proof of the EURO emission class to be deposited cannot be provided by the proofs and certificates mentioned in sub-items 1 to 5, provided that this confirmation (e.g. IG-Luft sticker allocation) was issued by the vehicle manufacturer itself or by a person expressly authorised by the vehicle manufacturer. Evidence that the letter is written by the manufacturer or evidence of the authorisation given to another party to write the letter of confirmation on behalf of the vehicle manufacturer must also be provided.

In the cases of subsections 2 to 6, a copy of the registration certificate (within the meaning of the KFG 1967, Federal Law Gazette No. 267/1967 as amended) or an equivalent certificate must also be enclosed with the verification documents for each motor vehicle, provided that this certificate was issued by a body authorised to issue it in the country in which the motor vehicle is registered.

The decision on the CO₂ emission class and/ or EURO emission class to be deposited is made on the basis of

- the documents submitted as evidence,
- the suitability of the documents submitted as evidence, and
- the information and evidence independently obtained by ASFINAG from third parties

hit. No evidence of a particle filter need be provided as this has no bearing on the toll rate.

5.2.5 Renewed declaration of rate-relevant characteristics

Irrespective of the rate-relevant characteristics stored in the toll system (CO₂ emission class, EURO emission class), a different CO₂ emission class and/or EURO emission class can be requested at any time by presenting the GO-Box at the GO point of sale.

Such a new declaration of rate-relevant characteristics is required in any case if the data stored in the toll system and shown on the last valid vehicle declaration do not or no longer match those of the motor vehicle in which the GO-Box is carried. If the declaration is not carried out properly, this

can in particular also lead to improper payment of the toll and thus to the offence of toll evasion being committed (see item 10).

An example of such a non-conformity and the resulting need for a new declaration can be the assignment of an existing licence plate number to another vehicle. This also applies accordingly to the use of test drive and transfer licence plates on different motor vehicles.

In the event of a new declaration of rate-relevant characteristics, an information document will be issued at the GO point of sale, which shows the now deposited (required) rate-relevant characteristics (CO₂ emission class and/or EURO emission class) as well as any associated behavioural obligations (e.g. possible expiry of a registration period). Reference is made to the alternative special regulation for the use of test drive and/or transfer licence plates (see item 5.6.6).

In addition to this verification document, a new vehicle declaration on the required and newly deposited rate-relevant characteristics will also be handed out at the GO point of sale in German and – if available – in the national language of the country of registration of the motor vehicle registration number, otherwise in English.

ASFINAG is entitled to request the registration holder to provide evidence again. This is the case, for example, if evidence has been provided for a motor vehicle in the past, but a GO-Box has not been issued for this motor vehicle within a reasonable period of time. The registration holder or a designated third party will be informed of the renewed obligation to provide evidence at the GO point of sale by means of a verification document in German and – if available – in the national language of the country of registration of the motor vehicle registration number, otherwise in English.

5.3 GO points of sale

It is possible to register for the toll system via a GO point of sale. GO points of sale are marked as such. A targeted search for GO sales outlets is possible at [-https://www.go-maut.at/go-vertriebsstellen](https://www.go-maut.at/go-vertriebsstellen). The customer also has the option of contacting the ASFINAG Service Centre (see item 14) to enquire about the location of the nearest GO point of sale. Shielding packaging for the GO-Box is provided at GO points of sale.

GO sales offices are labelled as follows (see complete illustration in Appendix 5):



Figure 20

Important note: Split GO boxes are only available at selected GO point of sale (see item 5.7). They can also only be exchanged at these GO points of sale (defect, etc.). You can find GO points of sale at <https://www.go-maut.at/go-vertriebsstellen>.

5.4 Processing fee

When registering for the toll system, a non-refundable processing fee of EUR 5.00 (including 20% VAT) must be paid for system access (registration for the toll system) for each GO-Box issued.

5.5 Payment Procedure

5.5.1 General information

Payment of the toll is possible either by billing afterwards (post-pay procedure) or by debiting a previously acquired toll credit (pre-pay procedure). The desired payment method must be specified when registering for the toll system and can subsequently be changed (as well as the payment method and means of payment) at the GO points of sale by presenting the GO-Box and a valid means of payment.

Information on which payment methods and means are authorised for the post-pay procedure and for the pre-pay procedure can be found in Appendix 2. This information is also available on the Internet at <https://www.go-maut.at> or via the ASFINAG Service Centre.

5.5.2 About the post-pay procedure

In the post-pay procedure, when using the road network subject to tolls with a motor vehicle subject to toll obligation, the toll section rates are added together and summarised daily to form billing rates. This charge is then collected using the appropriate method or means of payment.

If the post-pay process is selected, toll transactions will also be charged to the newly issued card in the event of renewal/ extension or replacement of the fuel card or credit card used due to theft, loss or expiry of validity. The card issuer shall notify ASFINAG of the card exchange or the renewal/extension of the card's period of validity.

If a card is or becomes blocked by the card issuer, the toll cannot be paid (see item 8.2.4.3.2). If in such a case no use is made of the option to pay the toll in arrears (see item 7.1), the driver fulfils the offence of toll evasion (see item 10).

5.5.3 About the pre-pay process

The toll credit in the pre-pay process must be topped up immediately with an amount of at least EUR 75.00 (including 20 % VAT) when the GO-Box is handed over to the customer. This also applies for each additional top up process. The amount of toll credit topped up is limited to a total of EUR 500.00 (including 20 % VAT) per GO-Box.

Every time the road network subject to tolls is used, the appropriate toll rate for the toll section that has been used is deducted from the toll credit balance. If the remaining toll credit is insufficient, no debit or partial debit will be made when passing through a toll collection point with a higher toll rate (than the existing toll credit). The driver is informed by a signal (sounds when passing through the toll collection station) that the toll has not been collected (see item 8.2.4.3.2). If, in such a case, the driver does not make use of the option to pay the toll in arrears (see item 7.1), he or she fulfils the offence of toll evasion (see item 10).

5.6 Data storage

5.6.1 General information

When a user registers with the toll system (system registration), the following data is stored:

- Country (state) where the vehicle that is liable for the toll is registered
- Registration number of the vehicle that is liable for the toll and the validity of a temporary registration number (optional), details of the motor trader
- Motor vehicle type (HGV and bus, whereby special vehicles and motorhomes are subsumed under the motor vehicle type HGV)
- Base category (2, 3 or 4)
- deposited EURO emission class
- stored CO₂ emission class
- Payment method and means of payment (including period of validity)
- GO-Box identification number (GO-Box number)
- Personal Account Number (PAN)
- First name and surname or company name of the registration holder (optional in the pre-pay procedure)
- Address of the registration holder (optional in the pre-pay procedure)
- Petrol, debit or credit card number (depending on the selected means of payment)
- Telephone number (optional)
- Fax number (optional)
- Email address (optional)
- Type of drive E/H2

ASFINAG Maut Service GmbH is authorised to store the above-mentioned data and any other data voluntarily provided.

5.6.2 Obligation to promptly disclose changes to the data to be stored in accordance with item 5.6.1

The driver and the registration holder are obliged to inform ASFINAG Maut Service GmbH immediately of any changes to the stored data as soon as such a change occurs. Failure to do so means that the driver and the registration holder bear sole responsibility for all negative consequences resulting from a failure to provide this information. In particular, the driver is obliged to notify any change in the motor vehicle registration number, CO₂ emission class and EURO emission class by presenting the GO-Box at a GO point of sale, otherwise the offence of toll evasion may be committed in accordance with item 10.

If the GO-Box identification number, the vehicle licence plate number, the CO₂ emission class or the EURO emission class is changed, a new vehicle declaration will be issued to the driver at the GO point of sale and the previous vehicle declaration will automatically lose its validity. In this case, evidence must be provided again in accordance with item 5.2 or, if the special regulations for test drive and/ or transfer licence plates are used, in accordance with item 5.6.6.4.

If changes are not carried out properly, this can in particular also lead to the toll not being paid properly and thus to the offence of toll evasion being committed (see item 10).

Changes to motor vehicle data (e.g. the motor vehicle registration number) must in any case be made at a GO point of sale and the GO-Box and the registration certificate must be presented.

To change the payment method (from post-pay to pre-pay or from pre-pay to post-pay), you must also visit a GO point of sale and present the GO-Box and a valid means of payment. In both cases, the new, amended data will be stored in the GO-Box.

The vehicle registration number and the PAN are all that are required to change data relating to the registration holder. This data can be changed by calling the ASFINAG Service Centre.

The data given in an application for exemption in accordance with item 3.3.2 is stored upon submission of such an application.

ASFINAG Toll Service GmbH is authorised to correct and complete of its own accord the data stored in accordance with item 5.6.1. This is most particularly the case in those situations where the driver and the registration holder do not meet their obligation to make changes to the data to be saved immediately. The customer's right to demand the correction and completion of data remains unaffected.

The stored data is deleted as soon as and as long as it is no longer required to collect the toll, charge costs, allow for processing, deal with complaints, or fulfil any other legal obligations.

5.6.3 Sale of motor vehicles

"Sale", within the meaning of the Tolling Regulations Part B, refers to all forms of change of registration holder of a motor vehicle subject to tolls.

5.6.3.1 Sale of a motor vehicle without an associated motor vehicle registration number and without a GO-Box

In the event that a registration holder sells the vehicle for which a GO-Box has been issued, the registration holder is obliged

- either to de-register and return the GO-Box in accordance with item 5.7.4 or
- to arrange for the stored data to be changed in accordance with item 5.6.1 before using the GO-Box in another motor vehicle subject to toll obligation,

otherwise the registration holder shall bear sole responsibility for the billing and payment of future toll transactions.

Before using the road network subject to tolls for the first time, the purchaser of the motor vehicle is obliged to re-register with the toll system by providing all the data outlined in item 5.6.1.

5.6.3.2 Sale of a motor vehicle with associated motor vehicle registration number and without GO-Box

If the holder of a registration certificate sells a motor vehicle for which a GO-Box has been issued, the owner is obliged to:

- either to de-register and return the GO-Box in accordance with item 5.7.4 or
- to earmark the GO-Box for a termination of the contract by calling the ASFINAG Service Centre. Before using the GO-Box in another motor vehicle subject to toll for the first time,

this reservation must be cancelled via the ASFINAG Service Centre and the stored data must be changed at a GO point of sale in accordance with item 5.6.1,

otherwise the registration holder shall bear sole responsibility for the billing and payment of future toll transactions.

Before using the road network subject to tolls for the first time, the purchaser of the motor vehicle is obliged to re-register with the toll system by providing all the data outlined in item 5.6.1. Before this new GO-Box is issued, the data to be newly stored in accordance with item 5.6.1 must be disclosed by the purchaser and a provisional reimbursement of costs must be paid as with item 5.7.2. This reimbursement will be refunded by ASFINAG Toll Service GmbH upon presentation of the purchase contract in question.

5.6.3.3 Sale of a motor vehicle without an associated motor vehicle registration number including GO-Box

In the event that the registration holder sells their vehicle without the corresponding motor vehicle registration number and passes on the GO-Box with the vehicle, the registration holder is obliged to immediately arrange for the stored data to be changed in accordance with item 5.6.1, otherwise the registration holder shall bear sole responsibility for the billing and payment of future toll transactions.

The purchaser must inform ASFINAG Toll Service GmbH immediately in writing of the takeover of the GO-Box, stating the GO-Box identification number together with the corresponding motor vehicle registration number, and enclosing a copy of the registration certificate with this letter.

If the purchaser fails to inform ASFINAG Toll Service GmbH of this change in ownership, they shall be solely responsible for not receiving a collective invoice with the relevant company data and that they will not be able to call up an itemised toll information sheet for the purchased motor vehicle using the SelfCare access data (i.e. the user name and password provided by ASFINAG Toll Service GmbH).

Any remaining toll credit allocated to a Pre-Pay GO-Box as well as any outstanding receivables in accordance with item 7.3, subsequent settlement, shall be automatically transferred to the purchaser in the event of the sale of the motor vehicle and transfer of the GO-Box with the motor vehicle. This is why it is the sole responsibility of the registration holder and the purchaser to reach agreement on such matters.

In case of termination of the contract, any remaining credit balance will be refunded to the means of payment with which this remaining credit balance was topped up.

5.6.3.4 Sale of a motor vehicle with associated motor vehicle registration number and GO-Box

In the event that the registration holder sells their motor vehicle with the associated motor vehicle registration number and passes on the GO-Box with the motor vehicle, the registration holder is obliged to immediately arrange for the stored data to be changed in accordance with item 5.6.1,

otherwise the registration holder shall bear sole responsibility for the billing and payment of future toll transactions.

The purchaser must inform ASFINAG Toll Service GmbH immediately in writing of the takeover of the GO-Box, stating the GO-Box identification number together with the corresponding motor vehicle registration number and enclosing a copy of the registration certificate.

If the purchaser fails to inform ASFINAG Toll Service GmbH of this change in ownership, they shall be solely responsible for not receiving a collective invoice with the relevant company data and that they will not be able to call up an itemised toll information sheet for the purchased vehicle using the SelfCare access data (i.e. the user name and password provided by ASFINAG Toll Service GmbH).

Any remaining toll credit allocated to a Pre-Pay GO-Box as well as any outstanding receivables in accordance with item 7.3, subsequent settlement, shall be automatically transferred to the purchaser in the event of the sale of the motor vehicle and transfer of the GO-Box with the motor vehicle. This is why it is the sole responsibility of the registration holder and the purchaser to reach agreement on such matters.

In case of termination of the contract, any remaining credit balance will be refunded to the means of payment with which this remaining credit balance was topped up.

5.6.4 Rental of motor vehicles

“Rental”, within the meaning of the Tolling Regulations Part B, refers to all forms of the temporary granting of a right of use to a motor vehicle subject to toll where the registration holder of the motor vehicle subject to toll does not change.

5.6.4.1 Rental of motor vehicles without GO-Box

In the event that there is no valid registration to the system for the rental vehicle, the renter must register to the system in accordance with the item 5.

In cases where the rented vehicle has already been registered with the system, but the renter has not been given the GO-Box, the renter is obliged to register with the system in accordance with item 5. Once they have done so, the GO-Box that was previously registered for this vehicle's motor vehicle registration number will be deactivated. Before the GO-Box is issued, the data to be newly stored in accordance with item 5.6.1 must be disclosed by the renter and a provisional reimbursement of costs must be paid in accordance with item 5.7.2. This reimbursement of costs will be refunded by ASFINAG Toll Service GmbH upon presentation of the rental agreement in question.

At the end of the period of rental, the renter is obliged to

- either de-register and return the GO-Box in accordance with item 5.7.4, or
- to earmark the GO-Box for a termination of the contract by calling the ASFINAG Service Centre. Before using the GO-Box in another motor vehicle subject to toll for the first time, this reservation must be cancelled via the ASFINAG Service Centre and the stored data must be changed at a GO point of sale in accordance with item 5.6.1,

Failure to do so means that the renter shall be solely responsible for the settlement and payment of future toll transactions.

5.6.4.2 *Rental of motor vehicles together with the associated GO-Box*

Before using the toll road network for the first time, the renter is obliged to provide their data in accordance with item, in particular their valid means of payment and the new billing data (in particular company name and billing address), via the ASFINAG Service Centre, on the Internet at <https://www.go-maut.at> and at any GO point of sale.

At the end of the rental relationship, the renter is also obliged to have the billing data and the means of payment disclosed deleted from the system via the ASFINAG Service Centre online or at www.go-maut.at and at any GO point of sale, otherwise the renter bears sole responsibility for the billing and payment of future toll transactions.

The provision of itemised toll information sheets in accordance with item 6 for the period of rental must be requested in advance by calling the ASFINAG Service Centre and providing evidence of the start and end of the rental period, whereby the RENTER must provide both the motor vehicle registration number of the rented vehicle, their invoice address, and any reference number for the collective invoice.

Any remaining toll credit allocated to a Pre-Pay GO-Box and any outstanding amounts in accordance with item 7.3, subsequent settlement, are automatically transferred to the new lessee or lessor if the motor vehicle is rented out and the GO-Box is passed on with the motor vehicle. It is therefore the sole responsibility of the lessee, the new lessor and the lessor to reach appropriate agreements.

In case of termination of the contract, any remaining credit balance will be refunded to the means of payment with which this remaining credit balance was topped up.

5.6.5 Interchangeable license plates

For motor vehicles that have only been assigned a single motor vehicle registration number (transferable number plates), the following regulation exists in accordance with the BStMG (Federal Road Toll Acts):

If these motor vehicles cannot be allocated to the same toll rate groups, all of the motor vehicles to which the transferable license plate was allocated are liable for the toll rate of the toll rate groups for which the highest toll rate has been specified.

In the case of a transferable number plate, the CO₂ emission class and the EURO emission class for which the higher toll rate is set must therefore be saved at the GO point of sale (see item 5.2), unless they are assigned to the same toll rate groups. This CO₂ emission class and this EURO emission class are generally stored for the transferable number plate and then applied to all vehicles assigned to the transferable number plates. Furthermore, all evidence for all motor vehicles assigned to the transferable number plate must be submitted to ASFINAG for inspection (see item 5.3).

5.6.6 Test drivers and motor transfer trips

5.6.6.1 General information

Companies that carry out test drives and/or transfer journeys and to which one or more test drive and/or transfer licence plates or equivalent foreign vehicle licence plates have been assigned by the authorities (hereinafter referred to as "transferors") can make use of the following alternative special regulations:

In amendment to item 5.2, the transferring party may register one or more test drive or transfer licence plates specified by it with ASFINAG for the toll system (see item 5.6.6.2). Test drive registration numbers and/or motor transfer license plates shall hereinafter jointly be referred to as 'motor transfer license plates'.

On the basis of the written registration, ASFINAG shall enter the registered motor trader registration numbers and the CO₂ emission classes for these registration numbers for which evidence has been provided as motor trader registration numbers in the toll system.

A separate declaration of the CO₂ emission class and/or EURO emission class at a GO point of sale for the transfer licence plate is only required if no CO₂ emission class and/or EURO emission class has been declared and verified for the transfer licence plate yet (see item 5.6.6.3). In this case, the registration form and the vehicle registration certificate must be submitted within 30 days of the declaration. Until such time as the registration is successfully completed, the provisions in item 5.2 shall apply.

For test drives and transfer journeys, it is generally the case that the vehicle declaration must be checked before the start of the journey (see item 8.2.4.1 and item 8.2.4.2), it must be ensured that

- 1) a CO₂ emission class and a EURO emission class that correspond to the same toll rate groups as the CO₂ emission class and EURO emission class of the respective motor vehicle with which the test and transfer journey is being carried out are stored on the GO-Box properly installed in the motor vehicle and that
- 2) the motor vehicle registration number that corresponds to the motor vehicle registration number stored on the GO-Box is properly affixed to the motor vehicle.

If the CO₂ emission class and/or EURO emission class and/or the motor vehicle registration number do not match the data stored, the driver must change the data (see item 5.6.2).

5.6.6.2 Registration and de-registration

The registration of motor vehicle registration numbers as transfer licence plates must be made using the application form provided by ASFINAG.

The application form, which is available in a variety of languages,

- Is available for download
 - in the SelfCare-Portal (<https://www.go-maut.at/selfcare-portal>) or
 - <https://www.go-maut.at/downloads>
- can be requested from the ASFINAG Service Centre.

The application form must be filled out, signed, and submitted to ASFINAG together with a copy of the vehicle registration certificate. The motor trader may submit the application form in one of a number of different ways outlined in item 5.2.3.1 It is not possible to submit the application

directly from a GO point of sale. The motor trader must be available to answer any questions ASFINAG might have.

Once ASFINAG has verified the application and if the outcome of the verification is positive, the indicated registration number shall be entered in the toll system as a motor trader registration number and the person who submitted the application shall be informed that both the application and the registration have been successful.

If the information provided by the person submitting the application is insufficient or if no information is provided or if there are other reasons that prevent a successful registration, the motor trader cannot be registered and the general provisions outlined in item 5.2 apply.

Applications to de-register motor traders must be made in writing. After de-registration, the general provisions outlined in item 5.2 apply.

5.6.6.3 Declaration of rate-relevant characteristics

As far as the obligation to make a declaration is concerned, ASFINAG differentiates between the following cases:

- a) *The CO₂ emission class and EURO emission class relevant for the respective transfer licence plate was already entered in the toll system before registration as a transferring party*

If a CO₂ emission class and EURO emission class have already been duly declared for the registered transfer licence plate in accordance with item 5.2 prior to registration as a transferor, this CO₂ emission class and EURO emission class will be used as the basis for the transfer licence plate. If a different CO₂ emission class and/or EURO emission class is to be stored for this transfer licence plate, a change must be made in accordance with c).

- b) *The CO₂ emission class and/or EURO emission class has not yet been entered for the respective transfer licence plate prior to registration as a transferor.*

The items 5.2.1 and 5.2.2 apply with the stipulation that in addition to a verification of the registration, the verification of evidence is carried out on a period-related basis (see item 5.6.6.4). Irrespective of the registration, a specific CO₂ emission class and/or EURO emission class must be requested at the GO point of sale for the transfer licence plate. After the deposit, a vehicle declaration and an information document indicating the obligation to provide period-related evidence are handed over to the GO point of sale. This information document is provided in German and - if available - in a language of the country of registration of the motor vehicle registration number, otherwise in English.

- c) *Change to a CO₂ emission class and/or EURO emission class already stored for a transfer licence plate*

In this case, item 5.6.2 applies.

5.6.6.4 Periodical provision of evidence

5.6.6.4.1 *General information*

As part of the registration process, the respective transfer licence plate is assigned a specific CO₂ emission class and EURO emission class on the basis of the registration certificate. The legality of the stored rate-relevant characteristics (i.e. the storage of a CO₂ emission class and EURO emission

class for the respective toll rate group, which corresponds to that of the respective motor vehicle with which the test and transfer journey is carried out) must be proven retrospectively for each period. Periods are defined as follows: the period of time between the 1st and the 15th of every calendar month or the period of time between the 16th and the last day of a calendar month.

The respective test drive and motor trader trip for which evidence must be provided is defined as the trip during which a specific vehicle is transferred to its respective place of destination.

For the first period of a calendar month (i.e. from the 1st to the 15th), the test and transfer journeys made must be listed together with relevant evidence and submitted to ASFINAG by the last day of the respective calendar month. For the second period of a calendar month (i.e. from the 16th to the last day of the month), the test and transfer journeys made must be listed together with relevant evidence and submitted to ASFINAG by the 15th of the following calendar month.

If the required CO₂ emission class and EURO emission class are assigned to the highest toll rate groups, it is not necessary to list and provide evidence.

If motor vehicles with different CO₂ emission classes and/or EURO emission classes that have been assigned to different toll rate groups are used for consecutive test and transfer journeys, the following must be checked before the start of the journey

- either the GO-Boxes (that were previously carried in the vehicle) and the registration number must be changed or
- data must be changed (see item 5.6.2).

In any case, the driver must check the vehicle declaration before the start of every test drive and motor trader trip (see item 8.2.4.1 and item 8.2.4.2) to ensure that

- a CO₂ emission class and a EURO emission class that correspond to the same toll rate groups as the CO₂ emission class and EURO emission class of the respective motor vehicle with which the test and transfer journey is being carried out are stored on the GO-Box properly installed in the motor vehicle and that
- the motor vehicle registration number that corresponds to the motor vehicle registration number entered in the GO-Box has been properly attached to the motor vehicle.

If several motor vehicle registration numbers and GO-Boxes are carried in the motor vehicle for subsequent test drives and motor trader trips, the driver must ensure that those GO-Boxes that are carried in the vehicle without actually being used are deactivated using the correct cover (see item 3.1.2 and item 8.2.4.1). If the GO-Boxes that are carried in the vehicle without actually being used are not deactivated in this way, toll transactions will be triggered or tolls collected automatically. If this happens, the collected tolls will not be refunded. It should be noted that in this context, it is the responsibility of the driver to take appropriate action in accordance with item 8.2.4.1 and item 8.2.4.2.

5.6.6.4.2 Evidence

All evidence required for the periodical provision of evidence and the lists must be submitted to ASFINAG by the motor trader by uploading the relevant documents via the SelfCare portal.

5.6.6.4.3 Verification of evidence

ASFINAG checks the legitimacy of the CO₂ emission class and EURO emission class stored for each test and transfer journey (see item 5.6.6.4.1).

As far as the verification of evidence is concerned, ASFINAG differentiates between the following cases:

- *Timely submission of verification documents for a correct CO₂ emission class and EURO emission class*
In this case, the periodical evidence is considered to have been correctly provided.
- *Timely submission of verification documents for an incorrect CO₂ emission class and/or EURO emission class*
In this case, a toll evasion offence in accordance with item 10 may have been committed for the relevant test drive and motor trader trip.
- *Documents are not submitted as evidence before the submission deadline*
In this case, a toll evasion offence in accordance with item 10 may have been committed for the relevant test drive and motor trader trip.
- *No documents were submitted as evidence.*
In this case, a toll evasion offence in accordance with item 10 may have been committed for the relevant test drive and motor trader trip.

5.7 Regulations for the GO-Box

5.7.1 General information

There are two types of GO-Boxes, namely the GO-Box and the split GO-Box (both also known as GO-Box for short), whereby GO-Boxes (and not split GO-Boxes) must be used in all motor vehicles subject to tolls without a metallised windscreen or with a metallised windscreen and a corresponding DSRC window (DSRC = Dedicated Short Range Communication). If the tolled vehicle has metallised windscreens (without a corresponding DSRC window), the customer must use a Split-GO-Box without exception. This will be provided at selected GO points of sale (see item 5.3).

ASFINAG Toll Service GmbH issues the customer with the GO-Box or the Split GO-Box for use exclusively with the motor vehicle registration number of the motor vehicle that is liable for the toll and has been registered with the toll system. GO-Boxes are issued free of charge, for a limited period that lasts until the toll system is completely discontinued, and for the sole purpose of using the GO-Box to pay the distance-based toll. This means that the customer and ASFINAG Maut Service GmbH conclude a contract of loan for use within the meaning of sections 971 onward of the General Civil Code (ABGB). At the end of the contractual relationship, the customer must therefore return the GO-Box or Split GO-Box to ASFINAG Toll Service GmbH (see item 5.7.4).

The customer or a third party attributable to the customer is responsible for looking after the GO-Box and handling it with due care for the duration of the loan period. In particular, any modification of the GO-Box, such as opening, labelling or recolouring of the GO-Box housing, as well as damage to or complete obliteration of the barcode and/or GO-Box identification number on the back of the GO-Box is not permitted. In cases where the GO-Box is damaged either due to intent or gross negligence—in particular in those cases mentioned above—the customer is obliged to pay the administrative fee outlined in item 5.7.2. The right to assert further claims for damages is reserved.

Claims for damages against ASFINAG and ASFINAG Toll Service GmbH shall be rejected unless caused intentionally or by gross negligence.

5.7.2 GO-Box: period of validity, guarantee, exchange, bearing of costs, and recall

5.7.2.1 Maximum period of validity of the GO-Box

Depending on the type of contract, the maximum GO-Box validity period is five years from the date of issue to the customer in the post-pay procedure and two years from the date of the last top-up of a toll credit in the pre-pay process. ASFINAG Toll Service GmbH is entitled to either recall a GO-Box with a view to replacing it or to deactivate a GO-Box before the end of its period of validity even if the GO-Box is being correctly used.

5.7.2.2 Guarantee

ASFINAG Toll Service GmbH grants the customer a five-year full operability guarantee from the date the GO-Box is issued to the customer. All malfunctions occurring within this period and measures to ensure GO-Box functionality will be rectified by ASFINAG Toll Service GmbH by replacing the GO-Box. During the guarantee period, the GO-Box shall be exchanged free of charge as long as the functional faults were not caused by the negligence of the customer or a third party attributable to the customer. In cases of doubt, the customer is obliged to pay the administrative fee (see below). If ASFINAG Maut Service GmbH is subsequently found to be responsible for the fault, this fee will be refunded if and in so far as the customer has submitted a written application (for a refund) to ASFINAG Maut Service GmbH. All claims are satisfied with the exchange of the GO-Box. After the end of the guarantee period, the customer is obliged to return the GO-Box (see item 5.7.4) and to register with the system again (see item 5.1). When re-registering with the system, the customer must pay the necessary processing fee in order to access the system (see item 5.4).

If, however, the customer or a third party attributable to the customer is responsible for the fault, ASFINAG Toll Service GmbH is entitled to charge the customer the following administrative fee (excluding VAT), depending on the amount of time that has passed since the GO-Box was issued to the customer.

after issue	for a GO-Box	for a Split-GO-Box
in the first year	EUR 60.00	EUR 200.00
in the second year	EUR 48.00	EUR 160.00
in the third year	EUR 36.00	EUR 120.00
in the fourth year	EUR 24.00	EUR 80.00
in the fifth year	EUR 12.00	EUR 40.00

5.7.2.3 Recall of the GO-Box

ASFINAG Toll Service GmbH will automatically recall a GO-Box before its validity period expires and for the purpose of replacing it. Failure to comply with this recall request will result in the GO-Box being automatically blocked (see item 8.2.4.3.2).

5.7.2.4 Locking the GO-Box

ASFINAG Toll Service GmbH is authorised to block the GO-Box in the event of technical defects or if irregularities are detected in connection with toll collection. Such irregularities in the collection of tolls, which entitle ASFINAG to deactivate the GO-Box, include cases where tolls that have been accrued by a driver cannot be collected properly. In these cases, a warning signal (see item 8.2.4.3.2) indicates that the GO-Box is blocked when driving through a toll payment point.

5.7.2.5 Exchange

The replacement of a defective GO-Box is only possible at a GO point of sale upon presentation of the registration certificate; the replacement of a defective Split GO-Box is only possible at selected GO points of sale (see item 5.3).

5.7.2.6 Legal consequences of blocking or using the road network subject to tolls despite expiry of the validity period

After expiry of the validity period or after the GO-Box has been deactivated, no toll transactions can be carried out with this GO-Box. If the driver uses the road network subject to tolls despite the expiry of the validity period or the deactivation of the GO-Box without availing of the option of retrospectively paying the toll (see item 7.1) – they shall be considered to have committed a toll evasion offence (see item 10).

5.7.3 Theft, loss, and deactivation of the GO-Box

The customer bears sole responsibility for the safekeeping of the GO-Box. In the event of the theft or loss of the GO-Box (hereinafter referred to as 'loss' for short), the customer must immediately inform the ASFINAG Service Centre, giving the relevant GO-Box number and PAN. The GO-Box will be deactivated once its LOSS has been reported. For the loss of the GO-Box, an administrative fee defined in item 5.7.2 must be paid before the new GO-Box (also known as a 'replacement GO-Box') is issued and at the latest within one month of reporting the loss. No other costs are accrued for the acquisition of a new GO-Box. The customer's obligations in the event of the theft or loss of petrol cards, credit cards, and debit cards depend on the provisions of the respective card issuer (however, see also item 5.5.2).

A lost GO-Box that is retrieved at a later date can only be reactivated by the ASFINAG Service Centre upon presentation of the relevant GO-Box number and PAN before a new GO-Box has been issued.

If a lost GO-Box is retrieved after a replacement GO-Box has been issued, the retrieved (old) GO-Box must be returned in accordance with item 5.7.4. Any remaining toll credit assigned to the old GO-Box was already assigned to the replacement GO-Box before it was issued.

5.7.4 De-registration, returning the GO-Box, and the lapse of toll credit

The customer de-registers from the toll system by returning the GO-Box. If it cannot be returned as a result of theft or loss, the customer must de-register by writing to ASFINAG Maut Service GmbH (see item 5.7.3).

The GO-Box must be returned directly to a GO point of sale or by sending it to ASFINAG Maut Service GmbH (see item 14), stating your name, address and bank details. In the event that a GO-Box contract cannot be cancelled directly at the GO point of sale using the pre-pay process, the corresponding GO-Box must also be sent to ASFINAG Toll Service GmbH. The provision of this data is only necessary for the pre-pay process. Bank details only need to be disclosed if a refund voucher is printed out in addition to the credit voucher. This takes place when a toll credit balance is refunded if the toll credit was topped up in cash or with a means of payment that is no longer accepted. Before sending the GO-Box, the customer must ensure that it is deactivated to avoid the triggering of toll transactions or the collection of tolls during transportation. Deactivating is done by telephone via the ASFINAG Service Centre, stating the PAN and the vehicle registration number. If a block is not initiated by the customer, any toll transactions or debits initiated as a result of the transport will not be refunded.

If there is still some unused toll credit when the GO-Box is returned (only applies to the pre-pay process), this sum will be refunded, whereby any unpaid tolls will be invoiced separately in accordance with item 7.3, retrospective billing.

If the unused toll credit is less than the last top up amount, the refund will be made in the form of the means of payment used for the last top up, i.e. either in cash (whereby a payment with Maestro is equivalent to a cash payment) or as a credit to a fuel or credit card. If the unused toll credit exceeds the last topped-up amount, the last topped-up amount will be refunded in the form of the means of payment used for the last top-up. However, the difference between the toll credit and the amount of the last top-up will be refunded in the form of the means of payment used for the penultimate top-up. This refund process, which is necessary due to the current credit and fuel card conditions, applies accordingly until the toll credit has been refunded in full.

If a GO-Box is sent to ASFINAG Toll Service GmbH by post using the pre-pay process, any unused toll credit will only be transferred if the name, address and bank details with the name of the account holder, IBAN and BIC (if the toll credit was generated by payment in cash, by Maestro or by a means of payment that is no longer accepted) have been provided.

Refunds to the bank account of the respective customer will only be made if the toll balance to be refunded exceeds a de minimis limit of EUR 5.00.

Toll credit (for the pre-pay process) is only valid for two years from the date of the last charging process (top-up). After this period, it is no longer possible to collect tolls. Two months before the end of this two-year period, the GO-Box sounds a warning signal when the vehicle passes a toll collection point (see item 8.2.4.3.1). Toll credit lapses five years after the last charging process (in other words, three years after the end of the period of validity) unless more toll credit is charged within this time or the GO-Box is returned. If the GO-Box is topped up again within this period, the total credit allocated to the GO-Box (old credit plus newly topped-up toll credit) becomes valid.

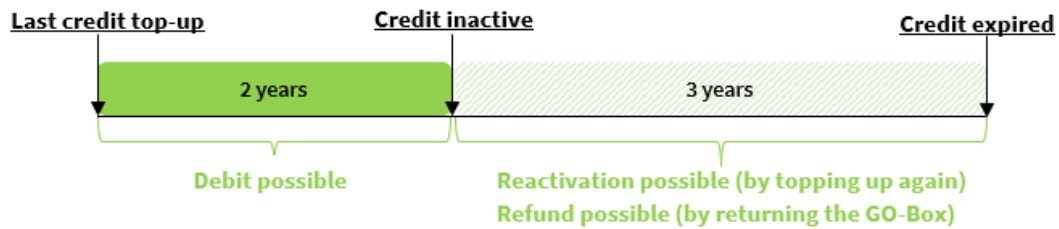

5.7.5 Transportation of GO-Boxes without the obligation to pay the toll obligation

The customer can also obtain shielded packaging for GO-boxes from GO points of sale (see item 5.3). If the GO-Box is simply being carried without there being an obligation to pay the distance-based toll (e.g. when being transported in a car), the transported GO-Box must be disabled by properly closing the shielded packaging (folding the packaging opening at least three times and then securing it with staples or adhesive tape).

If the GO-Box is not deactivated, a toll transaction or debit will occur for system-related reasons. If this happens, the collected tolls will not be refunded.

6 INDIVIDUAL SERVICE INFORMATION AND COLLECTIVE INVOICE

6.1 Itemised toll information sheets

Individual service information on the automatic toll transactions and the post-paid toll sections can be obtained (18 months retrospectively) either in paper form on request from the ASFINAG Service Centre for a fee of EUR 5.00 (including 20% VAT) per individual service information and motor vehicle or free of charge via the Internet at <https://www.go-maut.at/selfcare-portal> (SelfCare Portal).

Itemised toll information sheets for transaction and subsequent billing periods dating back more than 18 months will only be made available via the ASFINAG Service Centre against reimbursement of the internal expenses incurred by ASFINAG in individual cases as a result of the request.

An itemised toll information sheet is not an invoice; it is for information purposes only. No responsibility or liability will therefore be assumed for the timeliness, correctness, and completeness of the information contained in the itemised toll information sheets.

6.2 collective invoice

If billing is carried out via credit cards, ASFINAG cannot provide a balance confirmation due to a lack of actual knowledge of the payments made, but only a collective invoice showing the toll charges transferred to the credit card company for billing. All requests should be made to the ASFINAG Service Centre

A collective invoice is provided for a fee of EUR 5.00 (including 20 % VAT) per collective invoice.

7 RETROSPECTIVE PAYMENT OF THE TOLL

7.1 Retrospective payment at GO points of sale/toll enforcement officers

Vehicles duly registered for the toll system and equipped with an authorised on-board unit may be required to pay the toll subsequently in the event of non-payment or partial payment of the toll owed due to technical defects in the authorised on-board unit or the toll system, a pre-pay account balance that is too low, a blocked means of payment, the use of a GO-Box after expiry of the validity period in accordance with item 5.7.2, the use of an incorrect category or an incorrect toll rate group; however, without exception, only if all of the following conditions are met.

Retrospective payment can only be taken into account if they are made to the vehicle registration number used at the time of non-payment or partial payment.

- A subsequent payment for an improper toll transaction (no or only partial payment of the toll) can be made at a GO point of sale or to a TOLL ENFORCEMENT OFFICER (see item 9) in the course of the entry (stop), if the subsequent payment of the improper toll transaction is made within the POST PAYMENT AREA.
- The retrospective PAYMENT ZONE of a TOLL ENFORCEMENT OFFICER is 100 km (in both directions) on the road network subject to tolls, starting at the point where the driver was checked (i.e. the place they were apprehended).
- The retrospective PAYMENT DEADLINE of a GO point of sale is 100 km (in both directions of travel) on the road network subject to tolls, measured from the location of the GO point of sale (point of sale on the road network subject to tolls, e.g. motorway service area) or measured from the junction nearest to the point of sale (point of sale on the ancillary, non-toll road network).
- Retrospective payment is only permitted within five hours of the vehicle passing the first toll collection point at which the toll transaction was not correctly made (i.e. the toll was not paid at all or was only paid in part). The reference time of the toll system is used as a reference in this regard.
- Users of GO-Boxes must present them to the GO point of sale to make the retrospective payment.
- The driver of the vehicle that is liable for the toll must inform personnel at the GO point of sale or, if the driver is apprehended (stopped), the toll enforcement officer of the point where the toll was not paid or was only paid in part and, when requested to do so, provide information on how they intend to use the road network subject to tolls in the immediate future.

The toll rate to be paid and, therefore, the amount due is calculated on the basis of the information provided by the driver (regarding the toll station where the toll was not paid or was only paid in part, the actual number of axles on the motor vehicles at the time the toll was not paid or was only paid in part etc.), the presentation of any evidence (e.g. tachograph), and the presentation of the GO-Box (to avoid double payments, a comparison of the toll transactions stored in the on-board unit may be made). If the amount calculated in this way is lower than EUR 0.10, the amount shall be rounded up to EUR 0.10. An additional payment for a CO₂ emission class and/or EURO emission class that is assigned to a more favourable toll rate group than the actual (or actually proven) toll rate group requires that the driver of the motor vehicle discloses the CO₂ emission class and/or EURO emission class for which the difference is to be paid in the form of the retrospective payment.

If the driver is stopped by toll enforcement officers, the retrospective payment must be made directly to them. In the event that the GO-Box is not permanently affixed and in the event that an official vehicle license plate is not permanently affixed in a visible manner (see item 8.2.4.3), a retrospective payment can only be made at a GO point of sale and not directly to the toll enforcement officers.

In those cases for which, in accordance with item 7.3 in conjunction with item 8.2.4.3.3, an automated retrospective settlement of the improperly paid toll is carried out, retrospective payment is not obligatory.

7.2 Central additional payment if an incorrect category or incorrect toll rate group is used

If an incorrect category or incorrect toll rate group is used, in addition to the additional payment in accordance with the item 7.1, there is the further possibility of a central retrospective payment based on the customer's details within 96 hours of the first toll collection station at which the toll was not properly paid (i.e. only a partial payment of the toll).

The central retrospective payment can be made either by telephone via the ASFINAG Service Centre or online at <https://www.go-maut.at/selfcare-portal> (SelfCare Portal), provided that the following data is provided or entered:

- Personal Account Number (PAN)
- the GO-Box identification number of the GO-Box that was used at the time the toll was not correctly paid;
- the licence plate number entered in the GO-Box together with the country of registration
- Indication of the correct category, the correct CO₂ emission class and the correct EURO emission class
- the date and time when the toll was not correctly paid;
- provision of a valid means of payment in accordance with item 3.1.2 of Appendix 2 that can be used for central retrospective payment;
- the name and invoice address (for anonymous pre-pay customers) in cases where an anonymous pre-pay customer would like to receive an invoice.

In addition to selecting the motor vehicle concerned (licence plate number and country of registration) with the corresponding GO-Box identification number, it is necessary to specify the correct category, the correct CO₂ emission class or the correct EURO emission class and the period (date and time) for which the central retrospective payment is to be made. See Appendix 2 for the accepted means of payment.

Central retrospective payment is by all means only an option in those cases where at least one toll transaction was only partly paid during the period of time in question.

For technical reasons, central retrospective payment can only be made once for the given toll section and period; subsequent corrections after payment are not, therefore, possible.

Based on the information provided by the customer at the ASFINAG Service Centre or on the Internet (date and period on which the toll was not duly paid, etc.), the amount of the toll owed is determined and the amount to be paid is calculated. If the amount calculated in this way is lower than EUR 0.10, the amount shall be rounded up to EUR 0.10.

If the driver is stopped by toll enforcement officers, the retrospective payment must be made directly to them.

7.3 Retrospective settlement

ASFINAG has the right to bill customers automatically for tolls that have not been paid in situations complying with item 8.2.4.3.3 and in cases where ASFINAG has chosen not to erect a toll collection point on a specific toll section (see the fourth paragraph of item 1).

Retrospective billing only occurs in cases where a customer uses a road section subject to toll charging but where a toll transaction was not correctly made. The toll to be recalculated for the missing toll section corresponds exactly to the toll section rate to be paid in accordance with Appendix 4 of the Tolling Regulations at the time of the missing toll transaction. This applies equally to retrospective billing for both the pre-pay and post-pay processes.

Pre-pay procedure:

Each motor vehicle driver will be requested to pay the retrospectively charged amounts on the spot at the next customer contact at a GO point of sale following the improper payment of the toll. The customer will be given a special receipt for the retrospectively billed amount, which contains a detailed listing of the toll sections for which a toll was retrospectively billed. Toll credit can only be recharged, data changed, and contracts terminated once this retrospectively billed toll has been paid in full. It is not possible to offset the amount to be offset against any existing toll credit.

Post-pay procedure

In the post-pay process, retrospective billing is settled without any extra activity on the part of the customer; the retrospectively billed toll is simply added to the periodical collective invoices or petrol card invoices that are sent to the customer.

8 OBLIGATIONS OF MOTOR VEHICLE DRIVERS

8.1 The correct installation of the GO-Box

The GO-Box shall only be installed in the authorised vehicle that is liable for the toll and carries the registration number to which the GO-Box has been registered. It has to be permanently installed in the following part (see Figure 21):

- The GO-Box must be attached to the inside of the windscreen between the centre of the vehicle and the centre of the steering wheel.
- It must be attached to that part of the windscreen that is cleaned by the windscreen wipers and in such a way that the GO-Box control key faces the interior of the vehicle.
- The GO-Box is at least 10 cm above the windscreen wiper in the rest position and
- must be mounted at least 30 cm below the upper edge of the windscreen.
- The attached GO-Box must not impede vision while driving.
- An area of the windscreen surrounding the GO-Box with a radius of 10 cm must be kept free of all objects and vehicle parts (e.g. sun shades).
- The GO-Box should not be attached to the windscreen behind a strip of tinted glass.

- The driver is also obliged to keep all objects that could impair operation of the control keys away from the GO-Box.

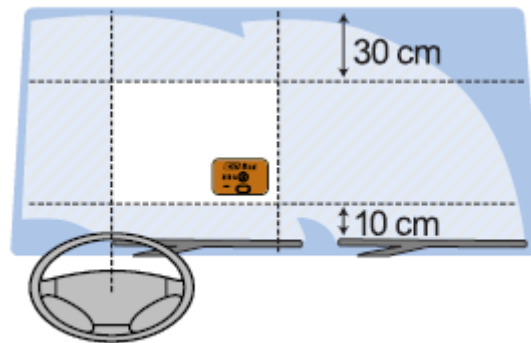

Figure 21: the correct installation of the GO-Box

The GO-Box may not be attached in a different area without prior single-approval in written form by ASFINAG Maut Service GmbH.

The installation of a Split GO-Box is subject to its own rules, which can be found in the respective operating instructions or the Split GO-Box Guide.

8.2 Proper operation of the GO-Box

8.2.1 Example illustration of the GO-Box

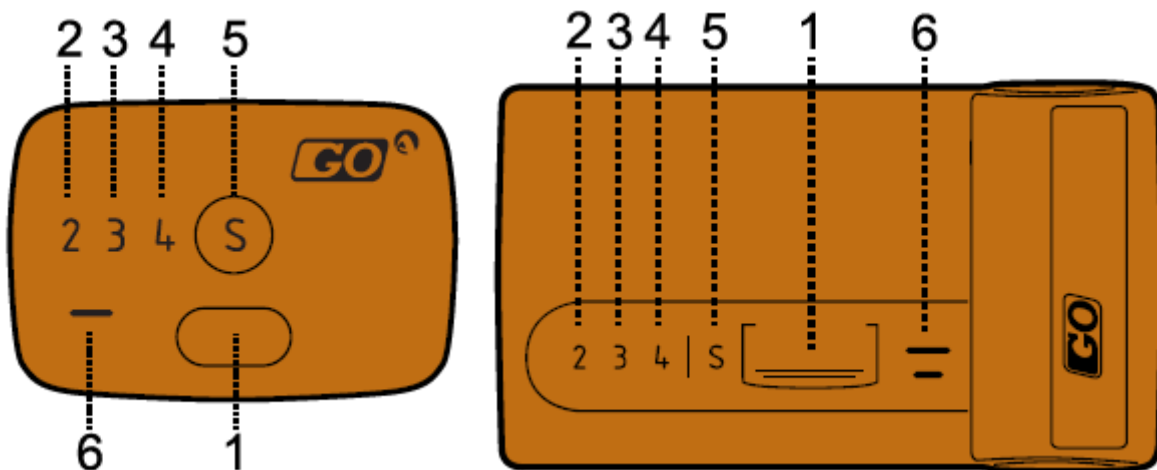

- 1 Operating button
- 2 Illuminated number: 2 axles
- 3 Illuminated number: 3 axles
- 4 Illuminated number: 4 or more axles
- 5 Illuminated letter S: Status of the GO-BOX
- 6 Buzzer: for acoustic signals

Figure 22

8.2.2 Declaration and setting of the category (not applicable for buses and motor homes)

When the GO-Box is issued, a base category is set for the vehicle that is liable for the toll on the basis of the vehicle's number of axles (the base category constitutes the lowest category that can be manually set). The driver is obliged to check the category in accordance with item 8.2.4.2 before starting each journey.

If a trailer or a road semi-trailer is attached to the vehicle, the driver is obliged to change the vehicle category to the correct category. The actual number of axles of the towing vehicle together with the number of axles of the (semi-)trailer is decisive for the declaration of the category to be set, irrespective of the maximum technically permissible laden mass of the (semi-)trailer. The user can increase the category by pressing the control key for longer than two seconds (the base category follows category 4 in the sequence). Once the category has been changed, the appropriate LED (category 2-4) will flash, thereby indicating the newly set category.

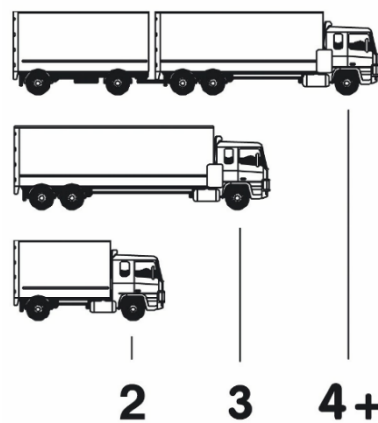

Figure 23

If the driver has mistakenly declared a higher category than the actual category of the vehicle or vehicle combination subject to the toll and an incorrect toll rate has therefore been charged or debited during the journey, ASFINAG shall reimburse the overpaid toll upon request after explaining the reasons and providing appropriate evidence. Applications for refunds must be accompanied by the corresponding evidence and submitted within three months of the date on which the excess toll was paid. Applications should be submitted directly to ASFINAG Maut Service GmbH (see item 14).

8.2.3 Declaring and setting the vehicle category (buses and motor caravans)

When the GO-Box is issued, a base category is set on the basis of the bus or motorhome's number of axles (definition given in section 2 para. 1 clause 28a of the Motor Traffic Act 1967) (see also the figure in item 8.2.2). It is not necessary to change the base category because trailers attached to buses or motorhomes are not taken into account when counting the number of axles.

8.2.4 Checking the functionality of the GO-Box

8.2.4.1 *The driver's duties*

Pursuant to Section 8 (2) BStMG (Federal Road Toll Acts), vehicle drivers must ensure that the GO-Box is in good working order before, during and after each journey on toll routes, report any malfunctions immediately, set the number of axles on the GO-Box and carry the evidence specified in item 5.2.3 that allows the assignment of a CO₂ emission class and a EURO emission class to the toll rate groups to be checked. The driver's general obligations also include the obligation to familiarise themselves with the meaning of the different GO-Box acoustic signals described in item 8.2.4.3 and to act in accordance with items 8.2.4.2 to 8.2.4.4. Furthermore, they should carry a shield package in the motor vehicle that is liable for the toll (see item 3.3.3).

The vehicle driver is obliged to check the vehicle declaration submitted in the course of declaring the CO₂ emission class and the EURO emission class in accordance with item 5.2. In addition, the driver is obliged to carry the latest vehicle declaration in the vehicle.

If the driver does not have the latest vehicle declaration, or if it is lost or damaged, then it must be reprinted at a GO point of sale via the SelfCare portal, or via the following link <https://www.go-maut.at/fahrzeugdeklaration/>.

In order to ensure that the data shown on the vehicle declaration carried is still valid, the driver can use the options mentioned under item 5.2 in addition to reprinting at a GO point of sale or via the SelfCare Portal, or via the following link <https://www.go-maut.at/fahrzeugdeklaration/>.

In the event of data changes, in particular relating to the motor vehicle registration number, the CO₂ emission class stored, the EURO emission class stored or the GO-Box identification number, a new vehicle declaration must always be issued at the GO point of sale; the old vehicle declaration then loses its validity. The process to be followed is regulated in item 5.6.2.

8.2.4.2 *Before starting the trip*

Before driving on the road network subject to tolls, the driver must make sure that the GO-Box is technically functional by pressing the control button once (for less than two seconds) (status check). The status request is only used to check the technical functionality of the GO-Box. The LED that lights up during the status check does not, however, inform the driver of any existing reasons for a deactivation of the GO-Box; the driver is only alerted to the payment or the non-payment of the toll by the various acoustic signals emitted by the GO-Box (for more information on the meaning of the acoustic signals and the actions the driver must take in response to these signals, see item 8.2.4.3).

The obligation to check that the GO-Box is in working order also includes the correct category declaration and setting in accordance with item 8.2.2.

- If both the "Status request" indicator light and the "Number of axles" indicator light briefly flash "green" once, this means that the system is technically functional.
- If the "Status request" indicator light flashes "red" twice briefly and the "Number of axles" indicator light flashes "green" twice briefly, this means that the system is technically functional.

- If the 'Status check' LED briefly flashes 'red' four times, no tolls can be collected. In this case, the driver must go immediately to the nearest GO point of sale or refrain from driving on the road network subject to tolls.
- If the 'Status check' LED and the 'Number of axles' LEDs do not flash (no flash), the GO-Box is not in working order. In this case the driver must immediately go to the nearest GO point of sale and fit their vehicle with a new functional GO-Box before continuing their journey (for replacement see item 5.7.2).

Before setting off, the driver must also check the latest vehicle declaration to ensure that

- the motor vehicle registration number affixed to the motor vehicle matches the official motor vehicle registration number shown on the vehicle declaration and
- whether the GO-Box identification number of the GO-Box being carried matches the GO-Box identification number shown on the vehicle declaration.

If the checked data does not match, the driver must visit the nearest GO point of sale and arrange for the data to be changed on the GO-Box carried in accordance with item 5.6.2. The difference in the toll accrued for the use of the sections of the road network subject to tolls used to reach the GO point of sale must be paid retrospectively in accordance with item 7.

Failure to do so may result in the driver committing a toll evasion offence in accordance with item 10.

8.2.4.3 *During the trip*

For the duration of the use of the road network subject to tolls, the GO-Box must be properly and permanently attached to the windscreen of the vehicle in accordance with item 8.1.

In order for the toll to be charged correctly, the driver must ensure, in accordance with § 102 KFG, that the official motor vehicle registration number of the motor vehicle subject to the toll is permanently visible and not illegible due to dirt, snow, damage or deformation.

Whenever the vehicle passes a toll collection point, the driver will hear the following acoustic signals. The driver should note the difference between acoustic signals that must be observed and those that provide information.

8.2.4.3.1 *The following signals provide information for the driver*

- A short beep: The toll payment is confirmed on the basis of the set category and the filed rate-relevant characteristics (CO₂ emission class, EURO emission class).
- Two short beeps: Although the toll payment is confirmed on the basis of the set category and the filed rate-relevant characteristics (CO₂ emission class, EURO emission class), it is still necessary to visit the next GO point of sale immediately.

Failure to do so can lead to the automatic deactivation of a GO-Box (see item 8.2.4.3.2).

This information signal is heard in the following cases in particular:

- the toll credit (only applies to the pre-pay process) has dropped below the limit of EUR 30.00 (the user must ensure that the toll credit is topped up in time),
- the toll credit will lapse within the next two months (only applies to the pre-pay process),

- the period of validity of the GO-Box will expire within the next two months,
- the data stored in the GO-Box must be changed,
- the customer is requested to exchange the GO-Box,
- to check the correct mounting of the GO-Box, or
- in connection with the expiring provision deadline for proof of rate-relevant characteristics.

8.2.4.3.2 *The following acoustic signal must be observed by the vehicle driver:*

•

This signal is heard in the following cases in particular:

- provisions in Tolling Regulations Part B were not observed by the customer,
- the GO-Box was deactivated as a result of a recall so that the GO-Box can be exchanged,
- - technical faults or observed irregularities relating to toll collection, or
- the toll credit in the pre-pay process is not sufficient to settle the toll amount due.

In this case, the vehicle driver is obliged to pay the toll retrospectively and in full in accordance with item 7.1. Failure to comply with this provision constitutes a toll evasion offence in accordance with item 10.

8.2.4.3.3 *No acoustic signal:*

If no acoustic signal sounds, no toll was paid. There is no obligation to pay the toll retrospectively in accordance with section as long as all of the following conditions are met without exception:

- The GO-Box is properly installed in accordance with item 8.1.
- At the time of passing through a toll collection point, a valid means of payment was saved for the GO-Box in the pre-pay process or the toll credit assigned to the GO-Box was loaded with a sufficient amount in the pre-pay process.
- The user checked that the GO-Box was in proper working order in accordance with items 8.2.4.2 and 8.2.4.4.
- The category of the vehicle that is liable for the toll has been correctly set in the GO-Box in accordance with item 8.2.2
- The registration number of the vehicle that is liable for the toll was correctly registered with the system in accordance with item 5.6.

If any one of these conditions is not met, the user is obliged to pay the toll retrospectively in accordance with item 7.1.

To verify the acoustic signals, the correct payment of the toll can be checked at any GO point of sale.

Drivers with a hearing disability are not exempt from these obligations. They are obliged to check that the toll has been properly paid at the aforementioned GO points of sale (see also item 8.2.4.4). Before doing so, the customer may also contact the ASFINAG SERVICE CENTER (see also item 5.3) to inquire whether the toll system is in working order.

8.2.4.4 *After the trip*

After all trips on the road network subject to tolls, the driver must once again check that the GO-Box is in technical working order and, if the GO-Box is not in proper working order (according to the provisions in item 8.2.4.2) must pay any unpaid or partially paid tolls by means of retrospective payment in accordance with item 7.1. Failure to comply with this provision constitutes a toll evasion offence in accordance with item 10.

9 MONITORING ADHERENCE TO THE TOLL OBLIGATION

9.1 Toll enforcement officers and their powers

Compliance with the payment of tolls based on mileage is monitored (in addition to automatic checks) by toll enforcement officers. The toll enforcement officers are organs of public supervision. They are appointed and sworn in in accordance with the provisions of Section 17 (2) BStMG (Federal Road Toll Acts).

For the purpose of checking that tolls have been paid correctly, the toll enforcement officers are empowered, among other things, to request drivers to stop by using clearly visible or audible signs, to stop them, to establish the identity of the driver and of the license holder, the motor vehicle, in particular the registration certificate, evidence of assignment to a rate group (in particular type certificate and vehicle declaration), the GO box or other on-board equipment, the tachograph, the odometer, the recording equipment in accordance with Regulation (EEC) No 3821/85 as last amended and - in the case of journeys with test or transfer license plates within the meaning of point 2 - to check evidence of the vehicle's tare weight (in particular a copy of the type certificate) and evidence according to item 5.2.4, and to orally ask stopped drivers to pay the substitute toll.



Figure 24

Furthermore, the toll enforcement authorities are authorised to divert motor vehicles to the toll checkpoints with the aid of automatic traffic guidance systems for the purpose of checking for proper payment of the toll and to carry out traffic surveys, currently A 1 Eberstalzell, A 1 Haag, A 1 Walserberg, A 2 Arnoldstein, A 2 Arnwiesen, A 2 Haimburg, A 2 Ilztal, A 6 Kittsee, A 4 Bruck/Leitha, A 4 Nickelsdorf, A 4 Gols, A 4 Zurndorf, A 5 Schrick, A 8 Kematen, A 8 Suben, A 9 Liesingau, A 9 Liezen, A 9 Schoberpaß, A 9 Straß, A 9 Trieben, A 9 Übelbach, A 9 Windischgarsten, A 10 Hoher Göll,

A 10 Kellerberg, A 11 Rosegg, A 11 Karawankentunnel, A 12 Kontrollbucht Roppener Tunnel Ostportal, A 12 Kontrollbucht Zirl Ost, A 12 junction Wörgl-Ost, A 14 Hörbranz, A 14 Nüziders, S 4 Pöttsching, S 3 Göllersdorf, S 16 Kettenanlegeplatz Bings, S 31 Hirm Nord, S 31 Hirm Süd and S 37 Maria Saal.

Additionally, toll enforcement officers may also monitor the correct payment of tolls and conduct traffic surveys at border crossings and junctions.

If the substitute toll is not paid and if criminal prosecution or enforcement of the penalty appears to be impossible or significantly impeded, toll enforcement officers are authorized in accordance with § 27 BStMG (Federal Road Toll Acts) to collect a provisional security or, until the stipulated provisional security is paid, to order the interruption of the journey in accordance with § 28 BStMG (Federal Road Toll Acts) and to prevent its continuation using suitable precautions (confiscation of the vehicle keys and documents, attachment of technical barriers to the vehicle to prevent it being moved, parking at a suitable location, etc.).

Provisional security deposits may be provided in cash (EUR) or using an authorised means of payment (Appendix 2).

9.2 Toll enforcement officers' identification cards

The identity card of the toll enforcement officers, which confirms their official capacity and which must be carried on duty or shown to those concerned upon request, is printed on both sides, is the size of a credit card and contains the following information in particular:



Figure 25

9.3 Toll enforcement officers' vehicles

The toll enforcement authorities' inspection vehicles are motor vehicles of the public security service pursuant to § 20 Para. 1 No. 4 lit a KFG 1967. These vehicles are silver-grey operational vehicles that are equipped with flashing blue lights and a siren. They are also marked with the following inscriptions: "ASFINAG", "Toll monitoring" and "ASFINAG Service and Control Service" (see Figure 26).



Figure 26

10 TOLL EVASION

10.1 Penalties for toll evasion

It is prohibited to drive a vehicle that is liable for the toll within the meaning of Tolling Regulations Part B on the road network subject to tolls without correctly paying the distance-based toll. In accordance with section 20(2) BStMG (Federal Road Toll Acts), drivers who violate this prohibition are in breach of an administrative rule and may be fined between EUR 300.00 and EUR 3,000.00 by the local district administrative authorities.

If the driver of a vehicle that is liable for the toll is apprehended on the road network subject to tolls and found not to have a GO-Box or another authorised on-board unit in the vehicle, they must leave the road network subject to tolls immediately at the next possible exit.

Should the registration holder not provide evidence of the legitimacy of the requested CO₂ emission class and/or EURO emission class in due time in accordance with the Tolling Regulations, the provisional allocation to the declared toll rate group will expire retrospectively (*ex tunc*) in line with section 9 subsection 11 BStMG (Federal Road Toll Acts). In that case the vehicle is assigned to the toll rate group with the highest rate retrospectively. Pursuant to § 20 para. 3 BStMG (Federal Road Toll Acts), owners of a vehicle who fail to provide proof of the vehicle's allocation to the declared CO₂ emission class and/or EURO emission class within the specified period and thereby cause the improper payment of the distance-based toll for the use of toll sections are committing an administrative offence. This breach of an administrative rule will be fined between EUR 300.00 and EUR 3,000.00 by the local district administrative authorities.

10.2 Non-imposition of a penalty

A penalty will not be imposed if a substitute toll - as described below - is paid. Any substitute toll duly paid in accordance with § 19 BStMG (Federal Road Toll Acts) cannot be reclaimed (§ 20 para 6 BStMG (Federal Road Toll Acts)).

10.3 Substitute toll

10.3.1 Method of payment

10.3.1.1 Apprehension by toll enforcement officers

If the driver is approached by toll enforcement officers, the toll may be paid retrospectively if the conditions mentioned in Item 7.1 are fulfilled. In the event of refusal to pay the retrospective

payment or if the conditions mentioned in item 7.1 do not exist, the toll enforcement officer is entitled to ask the driver to pay the substitute toll. The substitute toll is to be paid immediately upon request, either in cash (EUR) or with an approved payment method (Appendix 2). The vehicle driver shall be issued with a confirmation of the payment made and a list of the toll sections affected.

10.3.1.2 Retrospective summons process

If a violation is detected by toll enforcement officers during the course of their work or if the incorrect payment of the toll was detected through automatic checks without the driver being apprehended in person, the/a registration holder may receive a written request to pay the substitute toll. In cross-border procedures, the request for payment of the substitute toll is made in the form of an information letter in accordance with section 30b para. 1 of the BStMG (Federal Road Toll Acts), which is listed as a template in Appendix 7 to the Tolling Regulations.

In addition to the amount of the substitute toll to be paid, the written request also contains an identification number, which is stated as the payment reference, and the bank details.

The substitute toll must be transferred to the account specified in the request for payment or the information letter in accordance with section 30b para. 1 BStMG (Federal Road Toll Acts), stating the identification number or invoice number specified in the request. The request to pay the substitute toll will be complied with if it is credited to the specified account within four weeks of the request being issued and the transfer order contains the complete and correct identification number, which can be read automatically and is stated as the payment reference.

The substitute toll may not be paid in instalments. If partial payments are received, these will be refunded after deduction of a processing fee of EUR 15.00 (including 20% VAT). This also applies to late payments after filing a report with the competent district administrative authority and payments without stating the correct identification number given as the payment reference, as well as payments to an account other than the one disclosed on the copy of the request or the information letter pursuant to Section 30b para. 1 BStMG (Federal Road Toll Acts) for payment of the substitute toll. In the event of overpayments up to and including EUR 5.00, no money will be credited to the payer's account (otherwise the entire amount will be credited to the payer's account).

10.3.2 Substitute toll rate

The substitute toll rates (including 20% VAT) for the incorrect payment of the distance-based toll are given below:

REASON FOR SUBSTITUTE TOLL	SUBSTITUTE TOLL RATE
Not properly or timely provided proof of the declared CO₂ emission class, EURO emission class or the drive type of a vehicle with a pure electric drive unit or with a hydrogen fuel cell drive	EUR 240.00
Complete non-payment of the toll	EUR 240.00

<p>Partial payment of the toll</p> <p>1. Case Use of a wrong category (number of axles)</p> <p>2. Case Non-conformity</p> <p>a) a) the registration number attached to the vehicle is not the same as the registration number given in the vehicle declaration (toll rate-relevant vehicle registration number violation) or</p> <p>b) the GO-Box identification number of the GO-Box carried corresponds to the GO-Box identification number stated on the vehicle declaration and</p>	<p>EUR 120.00</p>
--	--------------------------

In the event of a coincidence of several acts, each of which separately represents a partial payment of the toll (i.e. coincidence of the partial payment of the toll after the first case and partial payment of the toll after the 2nd case), only a request for payment of the substitute toll or an information letter pursuant to section 30b para. 1 BStMG (Federal Road Toll Acts) is sent in the offence-relevant period.

10.3.3 Initiation of administrative penal proceedings

If a driver is apprehended and requested to pay a substitute toll or if following a written request, a substitute toll is not paid, is paid in part, or not paid on time, administrative penal proceedings shall be initiated.

11 DATA PROTECTION AND DATA SECURITY

ASFINAG is entitled pursuant to § 16a BStMG (Federal Road Toll Acts) to process the personal data required for toll collection, toll collection and the prosecution of toll evasion with the aid of automation.

To verify if the toll has been paid properly and to trace toll evasion, in accordance with section 19a BStMG (Federal Road Toll Acts), ASFINAG is entitled to use technical equipment. The image data and the vehicle license plate number and control data obtained from it may be processed for the purposes of collecting the toll, requesting payment of a substitute toll or the information letter pursuant to section 30b para. 1 of the BStMG (Federal Road Toll Acts) and prosecuting toll evasion.

More detailed explanations of the data protection principles and information on the rights of data subjects are available online at <https://www.asfinag.at/privacy>.

12 VIOLATION OF THE OBLIGATION TO STOP

Drivers who, contrary to section 18(2) BStMG (Federal Road Toll Acts), do not stop when instructed to do so by a toll enforcement officer are in breach of an administrative rule in accordance with section 21 BStMG (Federal Road Toll Acts) and shall be fined up to EUR 3,000.00.

13 PLACE OF JURISDICTION AND APPLICABLE LAW

The exclusive place of jurisdiction for all claims against ASFINAG under civil law arising out of these Tolling Regulations and/or the use of the road network subject to tolls shall be the court that has jurisdiction as regards such matters for the third district in Vienna. Only Austrian law applies, excluding the conflict of laws rules of private international law.

14 RESPONSIBILITY AND CUSTOMER SERVICE (ASFINAG Service Center)

ASFINAG has entrusted ASFINAG Maut Service GmbH with the operation of the toll system and the collection of the toll on behalf of and for the account of ASFINAG. ASFINAG Maut Service GmbH is the company to contact for all procedural questions relating to the distance-based toll.

ASFINAG Maut Service GmbH
Alpenstraße 99
5020 Salzburg, Austria
Austria

Telephone number: 0800 400 12 400 (free of charge from Austria and Germany)
Telephone number: +43 1 955 1266
Fax number: +43 1 955 1277
E-mail address / website info@go-maut.at
<https://www.asfinag.at>
<https://www.go-maut.at>

15 RATE GROUP FOR BUSES FROM 1 JANUARY 2025

In accordance with § 9 Para. 9 No. 4 BStMG, a separate rate group for buses (§ 2 No. 7 KFG) will be created from 1 January 2025, for which a reduction of 25% is to be provided in the rate groups for the charging of transport-related CO₂ emissions.

15.1 Declaration of the vehicle's status as a bus

In addition to the rate-relevant characteristics CO₂ emission class and EURO emission class, registration owners can also obtain provisional allocation to a rate group formed for buses and coaches before 1 January 2025. This declaration will be rate-relevant from 1 January 2025. The regulations in point 5.2. apply accordingly.

The declaration of the vehicle's status as a bus or coach can be made either by the vehicle licence plate holder or by a third party appointed by the vehicle licence plate holder. The regulations under item 5.2.1.1 on the declaration of the CO₂ emission class by the vehicle licence plate holder and the regulations under point 5.2.1.2 on the declaration of the CO₂ emission class by a third party designated by the vehicle licence plate holder, in particular the obligation to inspect and the associated rules of conduct, also apply mutatis mutandis to the declaration of the vehicle's status as a bus.

15.2 Proof and test of the vehicle's status as a bus or coach

If the deposit of the vehicle's status as a bus or coach has been requested, the legality of the requested and deposited rate-relevant characteristics must be proven to ASFINAG by means of suitable documents. Corresponding evidence can be submitted before 1 January 2025.

If the deposit of the vehicle's status as a bus or coach was requested before 1 January 2025, the 30-day provision period for verification documents relating to the declared status of the vehicle as a bus or coach does not begin until 1 January 2025 and these must be submitted to ASFINAG by 31 January 2025 (receipt) at the latest. The regulations under item 5.2.3 apply accordingly.

If no verification documents (see item 5.2.4) for the vehicle's status as a bus are submitted within the registration deadline, item 5.2.3.1.4 applies accordingly, whereby the vehicle will be retroactively assigned to the highest rate group from 1 January 2025 at the earliest (i.e. no reduction in the rate groups for the charging of transport-related CO₂ emissions).

PART C: INTEROPERABILITY

In order to pay the toll in Austria, customers may use other on-board units (OBUs) in accordance with section 7 BStMG (Federal Road Toll Acts) as long as these OBUs are authorised in accordance with the provisions below.

In order to use the authorised OBUs listed below, the provisions of Tolling Regulations Part B shall apply unless provisions are made in the items that follow for special cases and/or deviations.

Should a vehicle be used that has a pure electric drive unit or a hydrogen fuel cell drive unit pursuant to Part C, the specifications concerning the CO₂ emission classes and EURO emission classes (most notably evidence thereof) shall, in turn, also apply to these vehicles.

From 1 January 2024, the costs of traffic-related CO₂ emissions will be taken into account as external costs when determining the distance-based toll. To help customers determine the CO₂ emission class of their vehicle, ASFINAG provides a CO₂ emission class calculator (available at: <https://go-maut.at/co2-rechner>). Based on the values entered, the CO₂ emission class is determined and displayed as a purely informative result.

1 THE AUTHORISATION OF ON-BOARD UNITS USED FOR THE SWISS LSVA TOLL SYSTEM

1.1 General information

The Federal Office for Customs and Border Security in Bern, Swiss Confederation, on the one hand (hereinafter also referred to as "BAZG") and ASFINAG, represented by ASFINAG Maut Service GmbH, on the other hand (hereinafter also referred to as "ASFINAG") provide customers with a service (hereinafter referred to as "service") that enables customers of both toll systems to pay the toll both in Switzerland / Liechtenstein and in Austria using the Swiss on-board unit. The provision of this service does not affect the toll jurisdiction of either state.

Payment of the obligatory toll charges is still handled by the relevant toll collector (dual contract interoperability).

The following Swiss on-board unit is authorised for the payment of tolls in Austria in accordance with section 7 BStMG (Federal Road Toll Acts):

- emotach

The on-board unit can only be used to pay tolls in conjunction with the post-pay procedure (for details on the methods and means of payment that are accepted for this procedure, see Appendix 2 of the Tolling Regulations). Toll payment according to the pre-pay procedure is not possible.

The simultaneous use in a single motor vehicle of several on-board units that are authorised for electronic toll payment in Austria can lead to multiple toll payments and is therefore not permitted. If multiple charges are nevertheless made, the overpaid toll amount will be refunded upon request. For this refund, a flat-rate admin fee of EUR 50.00 plus 20% VAT will be charged for each on-board unit for which a refund is requested. The overpaid toll amount will only be reimbursed after the admin fee has been received by ASFINAG Maut Service GmbH.

1.2 Provisions relating to the on-board unit

The on-board unit may only be obtained from and returned to the BAZG in accordance with the conditions governing the Swiss LSVA toll system. It must be installed and kept operable in accordance with the standards of the LSVA toll system (see online at <https://www.bazg.admin.ch>). All questions regarding the on-board unit should be directed to the BAZG. ASFINAG cannot maintain, repair, or exchange the on-board unit.

1.3 Registration

1.3.1 Registration process

Before the on-board unit is used to pay tolls in Austria for the first time, the vehicle that is liable for the toll must be registered. The relevant registration forms, which are available on the internet at <https://www.go-maut.at/downloads> or from the ASFINAG Service Center, must be used for registration.

The person registering with the system will be informed in writing by ASFINAG whether the registration has been accepted by ASFINAG and the BAZG. If the registration is accepted, the BAZG will send the registration holder a chip card within a further ten days, which can be used to authorise the on-board unit in Austria. This card can be used to activate the on-board unit in Austria. The on-board unit indicates whether the unit is ready for use in Austria by displaying the codes '1001' or '1101' in the 'Gerät' (OBU) data field in the 'INFO/Fixe Daten/Vertrag' (Info/Fixed data/Contract) menu.

It is the sole responsibility of the customer to activate the on-board unit and to use the on-board unit properly in Austria.

Changes to customer data must be made using the forms available online at <https://www.go-maut.at/downloads> and via the ASFINAG Service Center.

ASFINAG will make use of its right of refusal in those cases in which proper tolling in Austria cannot be ensured using the Swiss on-board unit (in particular for vehicles with transferable number plates).

1.3.2 Declaration of rate-relevant characteristics (CO₂ emission class, EURO emission class) and data modification

Because the rate-relevant characteristics (CO₂ emission class, EURO emission class) is not stored in the on-board unit and because the on-board unit is permanently installed and cannot be presented at a GO point of sale, verification documents that are required as evidence may only be submitted in advance. To this end, the provision of a valid e-mail address or other contact address is absolutely essential.

On the calendar day following conclusion of the document verification process (see item 5.2.3 of Tolling Regulations Part B), the proven CO₂ emission class and/or EURO emission class will be entered in all toll gantries. Once this has occurred, this EURO emission class becomes relevant for the tolls to be paid. The claim to the billing of the toll rate for the proven CO₂ emission class and/or EURO emission class begins the moment the EURO emission class is correctly entered in the relevant toll gantry.

Once the document verification process has been concluded, the valid vehicle declaration will be sent to the customer either per e-mail or by post. Moreover, the vehicle declaration can be obtained at any time free of charge from a GO point of sale, the SelfCare portal or via the following link: <https://www.go-maut.at/fahrzeugdeklaration/>.

In the event of a data change, the verification documents suitable for proving the CO₂ emission class and/or EURO emission class in accordance with item 5.2.4 of Part B of the Tolling Regulations shall be submitted to ASFINAG for verification. Existing customers shall provide ASFINAG with the relevant verification documents in accordance with item 5.2 of Part B of the Tolling Regulations.

1.4 Data exchange

By registering with the system, the customer authorises the BAZG and ASFINAG to save and exchange data relating to the customer and the vehicle that is liable for the toll and that is required for use of the on-board unit.

In order to ensure that tolls are paid correctly in Austria, ASFINAG and the BAZG exchange the following data:

- Business partner number
- LSVa master number
- Vehicle license plate number and country of registration
- Personal Account Number (PAN)
- on-board unit identification number (OBU ID)

1.5 Obligations of motor vehicle drivers

1.5.1 The correct installation and operation of the on-board unit and the setting of the category in the on-board unit

The correct installation and operation of the on-board unit and the setting of the category are based on the relevant rules of operation for the on-board unit in use. For this reason, the on-board unit must be installed and kept operable in accordance with these standards.

Before beginning the journey, the driver must indicate on the on-board unit whether a trailer is attached to the vehicle. The declaration that a trailer is attached to the vehicle automatically triggers toll collection according to the rates in category 4.

1.5.2 Checking that the on-board unit is in working order

Once they have registered with the system, the vehicle driver must check before the start of every journey whether the on-board unit is working properly and whether toll payment in Austria is possible.

In the event that a toll payment in Austria cannot be made with the on-board unit, the customer shall be obliged to use an Austrian GO-Box in accordance with Part B of the Tolling Regulations or another on-board unit authorised in Austria by ASFINAG. The Austrian GO-Box can be obtained at any GO point of sale. It is expressly pointed out that the driver of the motor vehicle must in particular ensure that when changing to the Austrian GO-Box they also fulfil their obligations to

pay the toll in accordance with item 7 of part B of the Tolling Regulations. This is a very important point because failure to do so (i.e. failure to pay accrued tolls after switching to a GO-Box) can constitute a toll evasion offence in accordance with item 10 of Tolling Regulations Part B.

1.6 Signals emitted by the on-board unit

When the vehicle passes a toll collection point, the 'short' acoustic signal emitted by the on-board unit indicates that the toll has been paid.

If the toll has not been correctly paid, either a 'long' acoustic signal (e.g. the on-board unit has been disabled or the transaction has failed) is emitted or no acoustic signal is generated (no transaction made, e.g. because of a technical error). In such cases, the driver must pay the toll in accordance with item 7 of Part B of the Tolling Regulations.

However, the on-board unit does not have to be presented at a GO point of sale, but the on-board unit number or the vehicle registration number valid for Austria and the country of registration must be disclosed. Otherwise there is a possibility of the offence of toll evasion (see item 10 of Part B of the Tolling Regulations).

1.7 De-registration

Customers can de-register from the toll system at any time. However, de-registration must take the written form only. The letter of de-registration must be sent to:

ASFINAG Maut Service GmbH
ASFINAG Service Center
Schnirchgasse 17
1030 Vienna
Austria

ASFINAG will then deactivate the on-board unit. Once this has happened, the on-board unit can no longer be used to pay tolls in Austria. The deactivation of the on-board unit is indicated by the sounding of a 'long' acoustic signal when the vehicle passes a toll collection point in Austria. Within ten days of deactivation, the BAZG will send the holder of the registration certificate a chip card by post. The registration holder is obliged to insert this chip card into the OBU immediately to reverse activation of the on-board unit. This will stop the unit from generating a 'long' signal when the vehicle passes a toll collection point in Austria.

2 DUAL-CONTRACT INTEROPERABILITY WITH GERMANY ("TOLL2GO")

2.1 General information

Toll Collect GmbH (hereinafter also referred to as 'Toll Collect') on the one hand and ASFINAG, represented by ASFINAG Maut Service GmbH (hereinafter also referred to as 'ASFINAG'), on the other provide a service to customers that allows customers of both toll systems to use the German on-board unit (hereinafter referred to as 'TC OBU') to pay tolls in both the Federal Republic of Germany and in the Republic of Austria (hereinafter referred to as 'TOLL2GO service'). The provision of the TOLL2GO service does not affect the toll jurisdiction of either the Federal Republic of Germany or the Republic of Austria.

Payment of obligatory toll charges in Germany is still handled by Toll Collect and payment of obligatory toll charges in Austria is still handled by ASFINAG (dual contract interoperability).

2.2 Requirements for using the service in Austria

The applicant must be registered as a Toll Collect user and this registration must be active. They must also have a functioning TC OBU. This means that the TC OBU must have been provided by an existing Toll Collect service partner and correctly installed in the vehicle by the same in accordance with the relevant Toll Collect regulations before or at the latest by the time the application is submitted.

The TC OBU can only be used in Austria to pay tolls in conjunction with the post-pay procedure using the means of payment listed in Appendix 2. The TC OBU cannot be used in conjunction with the pre-pay procedure.

In order to avail of this service, TC OBU users must register separately and correctly with ASFINAG (see item 2.3 for details).

In the following cases in particular, the TC OBU cannot be used to pay tolls in Austria:

- vehicles with vehicle registration numbers containing Cyrillic characters or other special characters;
- vehicles with an active Swiss on-board unit that is being used to pay tolls in Austria;
- vehicles with transferable license plates;
- vehicles with vehicle registration numbers issued in Austria before 2 January 1990 (i.e. vehicle license plate numbers with white characters on a black background);
- vehicles with metallised windscreens;
- in other cases where it is not possible to ensure that the toll is collected correctly.

In these cases, ASFINAG will make use of its right to refusal.

The simultaneous use in a single motor vehicle of several on-board units that are authorised for electronic toll payment in Austria can lead to multiple toll payments and is therefore not permitted. If multiple charges are nevertheless made, the overpaid toll amount will be refunded upon request. For this refund, a flat-rate admin fee of EUR 50.00 plus 20% VAT will be charged for each on-board unit for which a refund is requested. The overpaid toll amount will only be reimbursed after the admin fee has been received by ASFINAG Maut Service GmbH.

2.3 Registration

2.3.1 Registering for the first time

Customers who have not yet registered for the Austrian toll system may, if they wish, conclude an initial contract with ASFINAG regarding the use of the TC OBU instead of using an Austrian GO-Box. If they decide to conclude such a contract, they do not need to acquire an Austrian GO-Box. A non-refundable processing fee of EUR 5.00 (incl. 20% VAT) per activated TC OBU and/or per TC OBU that has been cleared for use must be paid to access the system (to register with the toll system).

This requires that all the conditions set out below are met:

2.3.1.1 Registration process

Before the correctly installed TC OBU is used to pay Austrian tolls for the first time, the vehicle that is liable for the toll must be registered with the truck GO toll system in Austria.

Customers must register electronically as follows using the SelfCare portal:

Customers must register electronically on the website <https://www.go-maut.at/selfcare-portal>. During the registration process, the customer must provide the following information, which will be saved by ASFINAG and used for the purpose of toll collection:

- Toll Collect user number
- Country of registration
- Vehicle license plate number
- base category
- CO₂ emission class
- EURO emission class
- title
- Name
- Road
- house number
- Post code
- town/city
- Country of residence
- E-mail address
- Language
- Telephone number
- fax number
- card company
- card number (and possibly also the relevant card security code (CSC))
- Validity date

In order to use the TC OBU, the customer must accept Toll Collect's 'OBU-Einbuchung in Österreich' (OBU registration in Austria) conditions. The customer can accept these conditions on the SelfCare portal. In the event of failure to give consent, the TC OBU cannot be used. In this case, an Austrian GO-Box must be used for toll payment.

Once the required data has been entered, ASFINAG will transfer the following data to Toll Collect to complete the next stage of the registration process:

- Personal Account Number (PAN)
- Vehicle license plate number and country of registration
- base category
- CO₂ emission class
- EURO emission class
- on-board unit identification number (OBU ID)
- Toll Collect user number

On the basis of the data transferred by ASFINAG, Toll Collect GmbH will check whether the conditions for using the TC OBU to pay tolls in Austria are met.

If the conditions are met, Toll Collect will initiate activation and clearance for use. Activation and clearance for use is an automatic process during which relevant contractual data is stored in the TC OBU.

Following activation by Toll Collect, the vehicle registration numbers of those vehicles that have been cleared for use by Toll Collect for the TOLL2GO service will be transferred to ASFINAG. The customer will be informed both in an e-mail from ASFINAG and in the SelfCare portal of the fact that they can now use the TC OBU to pay tolls in Austria.

The fact that the OBU has been activated and cleared for use is also indicated on the TC OBU's display (for more information, please refer to the Toll Collect document 'Fahrzeuggerät Bedienungsanleitung' (On-board unit operating manual)).

If Toll Collect finds that the conditions for using the TC OBU to pay tolls in Austria are not met, the customer will be informed by ASFINAG both in an e-mail and in the SelfCare portal of the fact that the TC OBU cannot (at present) be used to pay tolls in Austria.

2.3.2 Switching from an Austrian GO-Box to the TC OBU

Customers that have already registered their vehicle for the toll system in Austria also have the option of paying the toll correctly using a TC OBU rather than the Austrian GO-Box.

In this case, the customer is obliged to return the Austrian GO-Box (see item 2.3.2.2) once the TC OBU has been activated and cleared for use. In this case, a processing fee does not have to be paid in order to activate/clear a TC OBU for use.

This requires that all the conditions set out below are met:

2.3.2.1 Registration process

Before the correctly installed TC OBU is used to pay Austrian tolls for the first time, the vehicle that is liable for the toll must be registered with the toll system in Austria.

Customers must register electronically using the SelfCare portal on the <https://www.go-maut.at/selfcare-portal> (SelfCare portal). The SelfCare portal lists the vehicle licence plates for which the TC OBU can be used in principle. Once the customer has entered their access data for the SelfCare Portal, they can select the vehicle licence plates listed in the SelfCare Portal for which they would like to use to TC OBU for toll payment.

In order to use the TC OBU, the customer must accept Toll Collect's 'OBU-Einbuchung in Österreich' (OBU registration in Austria) conditions. The customer can accept these conditions on the SelfCare portal. In the event of failure to give consent, the TC OBU cannot be used. In this case, the customer must use an Austrian GO-Box to pay the toll.

The customer is shown the data stored in the system (vehicle licence plate, country of registration, basic category and rate-relevant characteristics (CO₂ emission class, EURO emission class) for the vehicle licence plate selected by the customer. Once the data has been entered, the customer cannot change the data (with the exception of the base category) themselves. For more information on the rate-relevant characteristics, please refer to item 2.3.3.

During the registration process, the means of payment used for the post-pay procedure or the type of contract can also be changed (only from pre-pay to post-pay) (see item 2.6).

On the basis of the data transferred by ASFINAG, Toll Collect GmbH will check whether the conditions for using the TC OBU to pay tolls in Austria are met.

For information on the subsequent stages of the verification, registration, and activation process, please refer to item 2.3.1.1).

2.3.2.2 Obligation to return the GO-Box

Once the TC OBU has been activated and cleared for use by Toll Collect, the customer is obliged to return the Austrian GO-Box to any GO point of sale. The customer will be informed of the obligation to return the GO-Box by two acoustic signals emitted by the TC OBU and four acoustic signals emitted by the Austrian GO-Box (see also item 2.12.3). If the customer does not comply with this obligation to return the GO-Box, ASFINAG reserves the right to deactivate the German on-board unit for payment of the toll in Austria too. Once this happens, the German on-board unit can only be re-activated by returning the GO-Box or by paying a non-refundable administrative fee of EUR 60.00 at any GO point of sale.

2.3.3 Declaration of rate-relevant characteristics (CO₂ emission class, EURO emission class)

2.3.3.1 General information

If the TC OBU is used for toll payment in Austria, all relevant contractual data shall be allocated to the license plate number saved in the TC OBU in the course of activation and clearance for use.

With regard to the rate-relevant characteristics (CO₂ emission class, EURO emission class), the following should be noted in particular:

a) Evidence of rate-relevant characteristics has not yet been provided (e.g. in the case of registration for the first time)

A distinction must be made as to whether it is a CO₂ emission class (CO₂ emission class 2 or better) and/or EURO emission class (EURO IV or better) subject to mandatory verification or a CO₂ emission class (CO₂ emission class 1) and/or EURO emission class (EURO 0 to III) not subject to mandatory verification, which are assigned to the license plate numbers saved on the TC OBU:

In the case of rate-relevant characteristics requiring proof, proof of the CO₂ emission class and/or EURO emission class must be provided before registration in accordance with item 5.2 of Part B of the Tolling Regulations, otherwise a CO₂ emission class and EURO emission class not requiring proof will be assigned during the registration process. It is not possible to make an advance declaration at a GO point of sale.

In the case of rate-relevant characteristics requiring verification, Toll Collect can therefore only be commissioned to activate and authorise the TC OBU for toll payment in Austria after ASFINAG has completed its verification of the evidence.

b) Only when the TC OBU has been activated and enabled does the entitlement to the toll rate assigned to the respective toll rate group arise. Rate-relevant characteristics (CO₂ emission class, EURO emission class) have already been verified (e.g. change from the Austrian GO-Box to the TC OBU)

In the course of activation and clearance for use, existing contractual data provided by the customer is assigned to the license plate number saved on the TC-OBU, including the most recently evidenced and assigned rate-relevant characteristics for Austria.

If a different CO₂ emission class and/or EURO emission class is to be stored, see item c) below.

Only when the TC OBU has been activated and enabled by Toll Collect does the entitlement to the toll rate assigned to the respective toll rate group arise.

c) Changes to the rate-relevant characteristics (CO₂ emission class, EURO emission class)

Renewed verification of rate-relevant characteristics within the meaning of item 5.2 of the Tolling Regulations Part B is only required if the rate-relevant characteristics already assigned to the licence plate number saved on the TC OBU are to be changed.

ASFINAG shall check the verification documents submitted as evidence.

Until such time as relevant verification documents are submitted as evidence to ASFINAG, tolls shall be paid on the basis of the already allocated rate-relevant characteristics.

Once the verification of evidence has been completed, ASFINAG will arrange for Toll Collect to reactivate the TC OBU.

Only the positive completion of the verification of evidence and the reactivation of the TC OBU by Toll Collect as a result of the change will establish the right to be charged the toll rate assigned to the respective toll rate group.

2.3.4 Vehicle declaration

Following successful registration (i.e. once Toll Collect has activated the TC OBU and cleared it for use), the customer shall receive a vehicle declaration in accordance with item 5.2.1 of Tolling Regulations Part B.

Instead of the GO-Box identification number, the valid on-board unit identification number for Austria will be printed on the vehicle declaration.

If the stored vehicle data is changed in accordance with item 2.6, the original vehicle declaration will remain valid until such time as a new vehicle declaration is issued.

All vehicle declarations will be sent to the customer at the e-mail address provided by the customer. Moreover, the vehicle declaration can be obtained free of charge from a GO point of sale, the SelfCare portal or via the following link: <https://www.go-maut.at/fahrzeugdeklaration/>.

2.4 Right to refusal

Neither ASFINAG nor Toll Collect are obliged to approve use of the TC OBU for a specific vehicle. In fact, ASFINAG and Toll Collect have the right to refuse use either during the registration process or at a later date. If use is refused, the TC OBU cannot be used for toll payment in Austria. The right to assert claims against ASFINAG resulting from this refusal is expressly excluded.

2.5 The storage and exchange of data

When a customer registers, they expressly authorise Toll Collect and ASFINAG to exchange the data needed to allow the TC OBU to be used for toll payment in Austria. The following data is included in the exchange of information:

- General customer data, such as the Toll Collect user number.
- Technical data relating to the vehicle and the TC OBU insofar as the exchange of data is necessary for activation, clearance for use, and deactivation in accordance with items 2.3.1 and 2.3.2;
- data needed for toll payment in Austria:
 - Blocking and unblocking of the TC OBU (blocking data is only exchanged to the extent that a blocking and/or unblocking affects the toll payment in Austria).
- statistical data for the purpose of quality measurement and quality analysis of the TC OBU:
 - - total number of successful MTRs
 - - individual data sets relating to retrospective billing (LSID, timestamp)
 - - individual data relating to tolls that were not collected (LSID, timestamp).

Should a customer, for any reason whatsoever, wish to revoke their authorisation to exchange data, such revocation shall be notified to ASFINAG and Toll Collect in writing, stating the vehicle registration number and personal account number (PAN for short) affected by such revocation within the meaning of 5.6.1 of Part B of the Tolling Regulations. After receipt of the revocation, the TC OBU will be blocked by ASFINAG for toll payment in Austria and the Toll2GO service will be disabled by Toll Collect for the customer's affected vehicle license plates. Once the TC OBU has been disabled for Austria, tolls must be paid using the Austrian GO-Box.

Please note that for the period between ASFINAG's receipt of the revocation and the actual deactivation by Toll Collect, the TC OBU will emit four brief acoustic signals whenever it passes a toll collection station. The TC OBU will only stop emitting acoustic signals once Toll Collect has completed the technical deactivation of the TOLL2GO service.

2.6 Data changes

In derogation of item 5.6.2 of Tolling Regulations Part B, the following provisions apply to data changes:

a) Changing vehicle data

Changes must be sent to ASFINAG either via the SelfCare portal or in writing.

Registration at a GO point of sale is not possible.

b) Changing customer data

Customer data can only be changed in writing.

It is not possible to make customer data changes directly at a GO point of sale or in the SelfCare portal.

c) Changing the means of payment

The means of payment is the only data change that can be made directly at a GO point of sale. The means of payment can also be changed in the SelfCare portal or in writing. Please refer to Appendix 2.

Data changes that are submitted to ASFINAG in written form must be sent to the following address:

ASFINAG Maut Service GmbH
ASFINAG Service Center
Schnirchgasse 17
1030 Vienna
Austria

On the basis of the changes made known by the customer, ASFINAG will instruct Toll Collect to make the relevant data changes to the TC OBU.

Data changes that are made known to Toll Collect only are not binding for ASFINAG. Customers should note that not making relevant data changes known constitutes a toll evasion offence in accordance with item 10. ASFINAG will make every effort to enter data changes about which it subsequently finds out (especially changes to vehicle registration numbers). However, such changes will not have any effect on breaches of administrative rule that have already been committed.

2.7 The sale or rental of vehicles

The provisions in item 5.6.4.2 of Tolling Regulations Part B apply accordingly to the rental of vehicles.

If the holder of a registration certificate sells their vehicle, for which a TC OBU has been activated and cleared for use, they are obliged to inform ASFINAG of this fact in writing. If they do not do so, the holder of the registration certificate shall assume sole responsibility for the billing and payment of future Austrian toll transactions. The announcement of the sale is regarded as a written cancellation of the TC OBU, so it can no longer be used for toll payment in Austria (see item 2.10 Cancellation).

Before using the Austrian road network subject to tolls for the first time, the buyer of the vehicle is obliged to make a new registration for the toll system.

2.8 Provisions relating to the TC OBU

Toll Collect GmbH is the sole contact for matters relating to the TC OBU:

Toll Collect GmbH
PO Box 11 03 29
D-10833 Berlin
Germany

The relevant Toll Collect provisions shall apply to the installation, exchange, and return of the TC OBU. If the TC OBU is used to pay tolls in Austria, the driver must make sure that Toll Collect's conditions regarding installation and use are observed. In particular, the driver must make sure that the area above the DRSC module as well as an area 190 mm from the driver's side and 70 mm from the front-seat passenger are kept clear.

For this reason, all claims relating to the TC OBU should be addressed to Toll Collect, especially those claims relating to the provision of maintenance, repair, and exchange services. These services are provided either directly by Toll Collect or by a Toll Collect service partner.

In the event of theft, loss, and deactivation, item 5.7.3 of Tolling Regulations Part B shall apply accordingly, whereby in this case, no administrative fee is payable to ASFINAG.

Generally speaking, because the TC OBU is securely installed in the vehicle, it cannot be removed by either ASFINAG or the customer. In those cases where, in accordance with the provisions of Tolling Regulations Part B, the on-board unit has to be presented (in particular at the GO points of sale), customers using a TC OBU must provide the on-board unit identification number that is valid for Austria, the vehicle registration number, and the country of registration.

Both ASFINAG and Toll Collect are entitled to disable the TC OBU in the event of technical faults or if they discover irregularities in toll collection. The TC OBU will be disabled should certain technical error patterns arise (e.g. an accumulation of instances where tolls could not be correctly collected, incomplete transaction data etc.). If the TC OBU is deactivated, the driver will be notified of this fact by the sounding of four acoustic signals.

2.9 GO points of sale

GO points of sale are available to customers using the TC OBU for the following services in particular:

- Acceptance of retrospective payments
- Receipt of (possibly) returned "local" Austrian GO-Boxes
- Change in the Post-Pay means of payment
- Issuance of Austrian GO-Boxes
- the conclusion of rental contracts;
- information about the status of the TC OBU
- Issue of vehicle declarations
- the payment of administrative fees.

2.10 Deregistering the TC OBU

One or more TC OBUs can be deregistered for toll payment in Austria in writing at any time. The letter of de-registration must be sent to the following address:

ASFINAG Maut Service GmbH
ASFINAG Service Center
Schnirchgasse 17
1030 Vienna
Austria

Customers can also deregister their TC OBUs via the SelfCare portal.

Once ASFINAG has received the letter of deregistration, ASFINAG will immediately disable the TC OBU for toll payment in Austria. ASFINAG shall inform the customer by e-mail about the completion of the deregistration process. From this point on, toll in Austria must be paid using an Austrian GO-Box.

ASFINAG shall inform Toll Collect about the de-registration. Toll Collect shall immediately initiate the necessary deactivation of the TOLL2GO service on the TC OBU. Please note that for the period between ASFINAG's receipt of the revocation and the actual deactivation by Toll Collect, the TC OBU will emit four brief acoustic signals whenever it passes a toll collection station. The TC OBU will only stop emitting acoustic signals once Toll Collect has completed the technical deactivation of the service.

Customers should note that Toll Collect is also entitled to exclude the TC OBU from being used for toll payment in Austria. The customer must make sure in good time that tolls can be paid correctly in Austria, if necessary using an Austrian GO-Box. Customers should note that they are obliged to pay toll retrospectively in accordance with item 7 of Tolling Regulations Part B.

As soon as Toll Collect informs ASFINAG that a TC OBU has been excluded, ASFINAG will inform the customer by e-mail and via the SelfCare portal.

ASFINAG is not obliged to check whether Toll Collect's decision to exclude the TC OBU is legitimate and is not responsible for doing so.

2.11 Retrospective payment of the toll

In the event of improper toll payment, the customer shall pay the toll in accordance with item 7 of Part B of the Tolling Regulations. Both in the case of subsequent payment at a GO point of sale, for a toll enforcement officer and in the case of central retrospective payment, the on-board unit number valid for Austria, the vehicle license plate number and the country of registration must be disclosed.

Item 7 of Tolling Regulations Part B applies with the proviso that it is not possible to obtain information about toll transactions at GO points of sale because the TC OBU is securely installed in the vehicle and cannot, therefore, be presented at a GO point of sale.

For all details on the authorised means of payment, please refer to Appendix 2 of the Tolling Regulations.

2.12 Obligations of motor vehicle drivers

2.12.1 The correct installation and operation of the TC OBU and setting the category in the TC OBU

The proper installation and operation of the TC OBU as well as the setting of the category is governed by the applicable operating regulations of Toll Collect. For this reason, the TC OBU must be installed and kept operable in accordance with Toll Collect's standards.

If a trailer or a road semi-trailer is attached to the vehicle, the vehicle driver must set the vehicle category in the TC OBU in accordance with the Toll Collect document 'Fahrzeuggerät Bedienungsanleitung' (On-board unit operating manual) before using the road network subject to tolls. The actual number of axles of the towing vehicle together with the number of axles of the (semi-)trailer is decisive for the declaration of the category to be set, irrespective of the maximum technically permissible laden mass of the (semi-)trailer. The declared number of axles can be read on the display of the TC OBU.

2.12.2 Checking that the TC OBU is in working order

Once the TC OBU has been activated and cleared for use, the vehicle driver must check before the start of every journey whether the TC OBU is working properly and whether toll payment in Austria is possible.

For more information on how to do so, please refer to the Toll Collect document 'Fahrzeuggerät Bedienungsanleitung' (On-board unit operating manual).

In the event that the toll payment in Austria cannot be made with the TC OBU, the customer shall be obliged to use an Austrian GO-Box in accordance with Part B of the Tolling Regulations or another on-board unit authorised in Austria by ASFINAG. The Austrian GO-Box can be obtained at any GO point of sale. It is expressly pointed out that the driver of the motor vehicle must in particular ensure that when changing to the Austrian GO-Box they also fulfil their obligations to pay the toll in accordance with item 2.11. This is important because failure to comply with these obligations (changeover, retrospective payment) may constitute toll evasion in accordance with item 10 of Part B of the Tolling Regulations.

2.12.3 Acoustic signals emitted by the TC OBU

Vehicle drivers must pay attention to the acoustic signals emitted by the TC OBU while on the move. In case of irregularities, the nearest GO point of sale should be contacted, where an Austrian GO-Box can be obtained and an obligation to make retrospective payments as defined in item 2.11 Part C of the Tolling Regulations can be fulfilled.

In accordance with item 8.2.4.3 of Tolling Regulations Part B, the customer must observe the following acoustic signals emitted by the TC OBU, each of which is associated with different obligations:

- **ONE short signal tone (beep)**

This signal means that the toll payment is confirmed on the basis of the set category (number of axles) and the rate-relevant characteristics (CO₂ emission class, EURO emission class) assigned to the license plate number saved in the on-board unit.

- **TWO brief acoustic signals (beeps)**

Even if this double beep sounds, a toll payment has been made on the basis of the set category (number of axles) and the rate-relevant characteristics (CO₂ emission class, EURO emission class) assigned to the license plate number saved in the on-board unit. TWO short beeps mean that the driver is requested to contact the nearest GO point of sale. The customer will be informed directly at the GO point of sale about the further procedure (to be followed by them) (e.g. information that it is necessary to return a GO-Box).

Please note that a failure to observe this request can lead to the automatic deactivation of the on-board unit for toll payment in Austria.

- **FOUR short acoustic signals (beeps)**

The sounding of four beeps means that the toll was not paid correctly (e.g. four beeps are sounded when the on-board unit has been deactivated or alert the driver to a faulty transaction). In this case, the customer is obliged in accordance with item 2.11 to go to a GO point of sale within 5 hours and 100 kilometres and to retrospectively pay the toll for the relevant toll sections.

- **NO acoustic signal (no beep)**

No beep means that no toll was paid (e.g. when a transaction was not completed because of a technical error). The only time when the customer is not obliged to retrospectively pay the toll in accordance with item 7 of Tolling Regulations Part B is when the preconditions of item 8.2.4.3.3 of Tolling Regulations Part B are met.

- **Carrying both a TC OBU and an Austrian on-board unit in the vehicle simultaneously**

If a vehicle contains both the TC OBU and the Austrian GO-Box simultaneously, it is possible that one of these two on-board units might indicate by sounding four beeps that the toll was not paid. There is no obligation to make a retrospective payment according to item 2.11 only if the toll has been properly paid by the other on-board unit, which is indicated by one or two short beeps.

3 THE AUTHORISATION OF ON-BOARD UNITS FOR TOLL PAYMENT IN AUSTRIA WITHIN THE SCOPE OF THE “EUROPEAN ELECTRONIC TOLL SERVICE” (“EETS”)

3.1 European Electronic Toll Service (EETS)

In accordance with Directive 2019/520 of 19 March 2019 as amended and the associated Implementing Regulation EU 2020/204 and Delegated Regulation EU 2020/203 of 28 November 2019, the specifications for the EETS Domain of Autobahnen- und Schnellstraßen-Finanzierungs-Aktiengesellschaft (hereinafter "EETS Domain Statement"), as amended from time to time, are published on ASFINAG's website pursuant to section 7 BStMG (Federal Road Toll Acts) (<https://www.asfinag.at/maut-vignette/go-maut/eets>).

The EETS Domain Statement is an Appendix (see Appendix 8) to the present Tolling Regulations and is deemed to be an integral part of the European Electronic Toll Service (EETS).

The following provisions apply to customers of EETS providers (hereinafter "EA") who are authorised to operate in ASFINAG's EETS domain. The EETS domain of ASFINAG comprises the federal roads (motorways and expressways) in Austria that are subject to tolls.

ASFINAG is the toll charger in Austria in connection with the provision of EETS.

If the on-board unit (hereinafter also referred to as EETS-OBUE) has been approved by ASFINAG for toll payment in Austria, it shall be made available to the customer (hereinafter referred to as "EETS User") by the EA.

Toll payment in Austria for vehicles with the maximum technically permissible laden mass over 3.5 t is only possible for customers if the EETS OBU is activated for the EETS domain of ASFINAG.

3.2 Provisions relating to the on-board unit (EETS OBU)

An EETS OBU can only be obtained and returned from those EAs that also offer EETS for ASFINAG's EETS domain and whose EETS OBU is approved for toll payment in Austria.

EETS OBUs that are authorised for toll payment in accordance with section 7 BStMG (Federal Road Toll Acts) may, if EETS should be used, be authorised by the EA for toll payment in Austria.

The EAs authorised to pay tolls are listed in Appendix 2.

The sole contact person for the EETS User in connection with the EETS OBU is the respective EA of the EETS User. All claims regarding the EETS OBU are therefore to be brought against the EA, especially in relation to the rendering of maintenance, repair and replacement services.

The EETS OBU must be operated and kept serviceable in accordance with the instructions of the EA. With regard to the EETS User's obligations to cooperate in ASFINAG's EETS domain, reference is made in particular to item 3.5.

3.3 Registration with and de-registration from EETS

Registration with and de-registration from EETS falls solely within the remit of the respective service provider and is to be arranged between the service provider and the EETS user.

The provision and verification of evidence in connection with the rate-relevant characteristics (CO₂ emission class, EURO emission class) when using an EETS OBU is not the responsibility of ASFINAG. An additional provision of evidence at ASFINAG by the EETS user is not required. However, ASFINAG has the right to request from the EA those verification documents on the basis of which rate-relevant characteristics (CO₂ emission class, EURO emission class) subject to verification have been saved on the EETS OBU and the user list. The EA is obliged to comply with this request. However, when using EETS, the EETS user is required to check the vehicle declaration submitted by the EA and to carry it in the motor vehicle together with the required evidence (in accordance with Part B, item 5.2.4) in order to make it possible to verify the allocation of a CO₂ emission class and/or EURO emission class to a toll rate group.

3.4 The storage and exchange of data

By using EETS to pay tolls in Austria, the EETS User acknowledges that ASFINAG and the EA exchange, save and further process the data that is required for the EETS OBU to be able to communicate with ASFINAG and the EA.

- a) to ensure and carry out the toll payment in Austria or
- b) any violations of the prohibition to use the road network subject to tolls without properly paying the toll (toll evasion within the meaning of section 20 of the BStMG (Federal Road Toll Acts)) can be punished.

ASFINAG and the EA each act independently as data protection controllers.

3.4.1 Correct toll payment with the EETS OBU

In order to ensure that the EETS OBU can be used for toll payment in Austria, ASFINAG stores, processes and exchanges the following data in particular with the EA:

- vehicle-specific data
- Personal Account Number (PAN)
- on-board unit identification number (EETS OBU ID)
- Responsible EA
- data for deactivation and re-activation of the EETS OBU by the EA
- data for toll billing

By using EETS, the EETS User acknowledges that the above-mentioned data may be stored, processed and exchanged with the respective EA by ASFINAG for the purposes of toll billing and quality measurement and analysis.

3.4.2 Incorrect toll payment with the EETS OBU

In the event of improper payment of the toll (see in particular also Part B, item 10 "Toll evasion"), data required to send the registration holder a written request to pay the substitute toll or an information letter pursuant to Section 30b para. 1 BStMG (Federal Road Toll Acts) or to initiate administrative penalty proceedings may be transmitted to ASFINAG by the EA.

3.5 Obligations

3.5.1 Vehicle declaration

Before using the Austrian network of motorways and expressways, the EETS user is obliged to check whether:

- the vehicle registration number attached to the vehicle as well as the country of registration and
- the on-board unit number (OBU-ID) indicated on the EETS OBU

are the same as those given in the vehicle declaration.

If the data on the vehicle declaration does not match or there is no valid EETS contract, the intention to pay the toll with the EETS OBU must be abandoned, otherwise the offence of toll evasion may be committed (see item 10 of Part B of the Tolling Regulations).

In this case it is possible to pay the toll using the Austrian GO-Box according to part B of the Tolling Regulations (see also item 3.8).

Moreover, the EA is obliged to carry the vehicle declaration they received from the toll service provider and to show both this declaration and the documents that allow for verification of the allocation of a CO₂ emission class and/or EURO emission class to a toll rate group (in accordance with Part B, item 5.2.4) to officers in the event of an inspection.

If the service user needs to change any data (especially toll rate-relevant data), they must contact the relevant EA (see also item 3.7).

3.5.2 Installation and operation of the EETS OBU

The EETS OBU must be operated and kept serviceable in accordance with the instructions of the EA. The EETS OBU must be installed in accordance with the instructions of the EA and, when using the Austrian road network subject to tolls, in accordance with the regulations for the correct

installation of the Austrian GO-Box (see in particular item 8.1 of Tolling Regulations Part B). Otherwise there is a possibility of the offence of toll evasion (see item 10 of Part B of the Tolling Regulations).

3.5.3 Declaring and setting the category

Before the start of every journey, the EETS user must check and set the category. The actual number of axles of the towing vehicle together with the number of axles of the (semi-)trailer is decisive for the declaration of the category to be set, irrespective of the maximum technically permissible laden mass of the (semi-)trailer. The axles of a trailer are not taken into account when setting the number of axles for buses and caravans.

3.5.4 Checking that the EETS OBU is in working order

The EETS user must check whether the EETS OBU is in working order before, during, and at the end of every trip. In the event that the EETS OBU cannot or could not be used to pay the toll in Austria, an Austrian GO-Box should be used (see also item 3.8). It is expressly pointed out that in the event of improper toll payment, the EETS user must comply with their obligations to pay the toll retrospectively in accordance with item 3.6. Failure to comply with this obligation can constitute a toll evasion offence in accordance with item 10 of Tolling Regulations Part B.

In the event that several EETS OBUs are used for one motor vehicle, the EETS user must ensure prior to each trip that only one single on-board unit is active for electronic toll payment in Austria. Please note that the simultaneous use of several on-board units that are authorised for electronic toll payment in Austria can lead to multiple toll payments. It is expressly pointed out that the simultaneous use of several on-board units registered in Austria for electronic toll payment in the same motor vehicle may result in multiple toll payments. Therefore, the simultaneous use of several such on-board units is not permitted. If multiple charges are nevertheless made, the overpaid toll amount will be refunded upon request. For this refund, a flat-rate admin fee of EUR 50.00 plus 20% VAT will be charged for each on-board unit for which a refund is requested. The overpaid toll amount will only be reimbursed after the admin fee has been received by ASFINAG Maut Service GmbH.

3.5.5 Acoustic signals emitted by the EETS OBU

EETS users must pay attention to the acoustic signals emitted by the EETS OBU while on the move. In the event of irregularities, the EETS user must visit the nearest GO point of sale where they can obtain an Austrian GO-Box (see also item 3.8) and meet their obligation to make retrospective payments (see also item 3.6).

In accordance with item 8.2.4.3 of Tolling Regulations Part B, the customer must observe the following acoustic signals emitted by the EETS OBU, each of which is associated with different obligations on the part of the EETS user:

- **ONE** short signal tone (beep)
This signal means that the toll payment is confirmed on the basis of the set category (number of axles) in the EETS OBU and rate-relevant characteristics (CO₂ emission class, EURO emission class) saved in the user list.

- **TWO** short signal tones (beeps)
Two short beeps mean that the toll payment is confirmed on the basis of the set category (number of axles) in the EETS OBU and rate-relevant characteristics (CO₂ emission class, EURO emission class) saved in the user list. The EA will be happy to provide information on any EETS user obligations.
- **FOUR** short acoustic signals (beeps)
FOUR beeps means that the toll was not correctly paid. In this case, the EETS user is obliged in accordance with item 3.6 to go to a GO point of sale and to retrospectively pay the toll for the relevant toll sections. The EA will give information about any action that the EETS user is required to take, such as the replacement of the EETS OBU.
- **NO** signal tone (beeps)
No beep means that no toll payment has taken place. The only time when the customer is not obliged to retrospectively pay the toll in accordance with item 3.6 of Tolling Regulations Part C is when the preconditions outlined in item 8.2.4.3 of Tolling Regulations Part B are met. The EA will give information about any action that the EETS user is required to take, such as the replacement of the EETS OBU or the correct installation and operation of the EETS OBU.

3.6 Retrospective payment of the toll

In the event of incorrect toll payment, the EETS user shall pay the toll in accordance with item 7 Tolling Regulations Part B. Otherwise there is a possibility of the offence of toll evasion (see item 10 of Part B of the Tolling Regulations). The following specific provisions apply when using EETS:

The EETS OBU must not be presented at a GO point of sale. Instead, the vehicle declaration must be presented as a means of identification. Alternatively, the motor vehicle registration number and the country of registration can be provided.

It is not possible to obtain information about toll transactions at a GO point of sale.

The retrospective payment of the toll at a GO point of sale is made only on request and in accordance with the information provided by the EETS user (in particular toll sections used but not correctly paid for, number of axles, rate-relevant characteristics), as only the EETS user can determine when and where a toll was not paid.

The retrospective payment is made directly to ASFINAG (in other words not via the EA). For all details on the authorised means of payment, please refer to Appendix 2 of the Tolling Regulations.

No provisions are made for retrospective payment in conjunction with the rate-relevant characteristics because the EA will already have checked the EURO emission class.

In the event of an unsuccessful transaction by the EETS User, retrospective payment of the toll is in principle possible at GO points of sale and to toll enforcement officers in Austria using the means of payment accepted there, but not via the means of payment used within the scope of EETS (=EETS means of payment). The retrospective payment must be made in accordance with the specifications in the Tolling Regulations.

3.7 Responsibilities and services

3.7.1 EETS provider (EA)

As a rule, the EETS user must always contact their EETS provider (EA) first. EETS users must therefore always contact the service provider in the following exemplary cases:

- Registration with and de-registration from EETS
- handover and personalisation of the EETS OBU
- Checking the rate-relevant characteristics (CO₂ emission class, EURO emission class)
- Issue of vehicle declarations
- Payment process, especially accounting and information
- Data changes, in particular vehicle data, data of the EETS user, means of payment
- Disabling and re-enabling of the EETS OBU (e.g. in the event of the loss of the EETS OBU)
- Maintenance, repair, and exchange services relating to the EETS OBU
- Information regarding the sale or rental of vehicles using EETS

3.7.2 GO points of sale

GO points of sale are available to users of EETS in the following cases in particular:

- Acceptance of retrospective payments
- Issuance of Austrian GO-Boxes
- Receipt of (possibly) returned "local" Austrian GO-Boxes

3.7.3 ASFINAG Service Center

EETS users can call the ASFINAG Service Center using one of the following numbers: 0800 400 12 400 (when calling from inside Austria) or +43 1 955 1266 (when calling from outside Austria). The ASC is on hand to take central retrospective payments in the event of the use of the wrong category (number of axles) and to answer any general questions and issues relating to the Austrian toll system.

3.7.4 Special features

EETS users cannot use the services and functions of the SelfCare portal. Likewise, ASFINAG Maut Service GmbH shall not provide the EETS user with itemised toll information sheet or a collective invoice (in accordance with item 6 of Part B of the Tolling Regulations). The services available depend on the respective EA. The EA reserves the right to amend the type and scope of these services.

3.8 Use of the Austrian GO-Box

In the event that the EETS OBU cannot (properly) be used for toll payment in Austria, the EETS user is obliged to use an Austrian GO-Box or another on-board unit approved in ASFINAG's EETS domain. The Austrian GO-Box can be obtained at any GO point of sale. It is expressly pointed out

that the EETS user must ensure in particular that when switching to the Austrian GO-Box they also meet their obligations to pay the toll in accordance with item 3.6 of part C and item 7 of part B of the Tolling Regulations. This is important because failure to comply with these obligations (changeover, retrospective payment) may constitute toll evasion in accordance with item 10 of Part B of the Tolling Regulations.

In the following cases in particular, the toll in Austria must be paid using an Austrian GO-Box:

- if the EETS OBU experiences a technical failure;
- if the EETS OBU is de-activated;
- if the data on the vehicle declaration is not the same as the registration number attached to the vehicle, the country of registration of the vehicle, and the OBU ID of the EETS OBU.

Please note that the simultaneous use of several on-board units that are authorised for electronic toll payment in Austria can lead to multiple toll payments. It is expressly pointed out that the simultaneous use of several on-board units registered in Austria for electronic toll payment in the same motor vehicle may result in multiple toll payments. Therefore, the simultaneous use of several such on-board units is not permitted. If multiple charges are nevertheless made, the overpaid toll amount will be refunded upon request. For this refund, a flat-rate admin fee of EUR 50.00 plus 20% VAT will be charged for each on-board unit for which a refund is requested. The overpaid toll amount will only be reimbursed after the admin fee has been received by ASFINAG Maut Service GmbH. However, if two or more on-board units are installed or carried in a motor vehicle, the EETS user is responsible for using or activating the corresponding on-board units for the specific EETS domain.

- End -